

# CRESTWOOD POOLS

## The *Ultimate* On-Ground Pool

*Thank you for purchasing a CRESTWOOD POOL. We have incorporated over 100 years of combined pool experience with the finest materials and workmanship to provide your family with years of enjoyment and trouble free service.*

### Oval Installation Manual

The wood used in your Crestwood Pool has been preserved by pressure treatment with an EPA - Registered Pesticide containing Copper Azol (CA) in order to protect it from insect attack and decay. CA penetrates deeply and remains in the pressure-treated wood for an extended period of time. Exposure to CA may present certain hazards. Therefore, the following precautions should be taken, both when handling the treated wood and in determining how to use or dispose of the treated wood:

- Dispose of treated wood by ordinary trash collection or burial. Treated wood must not be burned in open fires or in stoves, fireplaces or residential boilers because toxic chemicals may be produced as part of the smoke and ashes.
- After working with the treated wood, and before drinking, eating or use of tobacco products, wash exposed areas thoroughly.

### CARE & MAINTENANCE

Even though your Crestwood Lumber has been pressure-treated with CA to inhibit fungus and bacteria that attack wood and cause decay, it is not waterproof. Water is still absorbed into and evaporated from the wood, which in time can cause discoloration, splits or checks. There is a full line of water repellent coatings and stains available through your Crestwood Pools, Inc. authorized dealer. These products are highly recommended to preserve the natural beauty of your Crestwood Pool and will help keep your investment looking like new.

**Please Note:** The wood has been Kiln Dried After Treatment and can be coated prior to or upon completion of the wall installation. **No** waiting time is necessary.

## ~~NOTE TO INSTALLER~~

It is extremely important that the following items be discussed with the Homeowner. After reviewing these precautions with the Homeowner, you **MUST** leave this Manual, Warranty Cards, and all Warnings with the Homeowner. It is also **REQUIRED** that all Warning Labels be applied to the liner and that the Safety Placard is installed at the entry point to the pool.

**WARNING!!** This swimming pool is **NOT** designed for Diving, Jumping, Sliding, Walking / Sitting on Top of Pool Wall. Serious or Fatal Injury can result from performing any of the above. Warning signs provided with pool kit **MUST** be displayed prominently and permanently throughout each swimming season. It is the Homeowners responsibility to do the following:

- Do **NOT** locate pool near objects that would entice diving ( i.e. garages, trees, porches, etc. )
- Do **NOT** allow anyone to use your pool unless they are fully aware of the warnings listed above.

**THIS POOL HAS BEEN DESIGNED FOR SWIMMING ONLY!**

Do **NOT** place CHLORINE or BROMINE directly on LINER as BLEACHING will occur.

The liner manufacturer, Pocono Pool Products, recommends that all Homeowners initially and annually have the areas where the pool and filtration system will be installed inspected and/or treated for termites, ants and other insects. Some customers have experienced damage to their PVC Plumbing and Vinyl Liners due to insect infestation. Insect damage to the Liner or Plumbing/Filtration system is not covered under any of the warranties accompanying your pool therefore we strongly recommend that all customers take these precautionary measures. Additionally, there is a rising occurrence of micro-bacteriological staining of liners. These micro-organisms are present in the soil and ingest the vinyl as a food source. The resulting secretions can cause discoloration, staining and/or the removal of the printed surface. To date no treatment exists to eliminate or diminish this problem. The vinyl calendaring companies and the pool industry as a whole are aware of these problems and are working for a solution. Should any treatment or preventative become available we will incorporate it into our product line immediately.

**IMPORTANT:** In Cold Climates there is a possibility of Frost Damage when Decking is built around only a portion of the pool and/or or if there is improper drainage. A differential in ground movement can occur due to snow acting as an insulator around the exposed portion of the pool while having no/or less snow under the decking and/or water in the ground due to improper drainage. Making sure there is proper drainage and placing snow under the decking should avoid the potential of Frost Damage. Insulating around the entire pool prior to the ground freezing is another alternative.

**IMPORTANT:** It is recommended to monitor the water level for a possible leak for 1 week prior to closing the pool for the winter. Closing the pool with a leak can cause liner/structural damage. It is possible to patch the liner under water, draining the water is **NOT** required.

Thank you for your understanding on the issues/info presented above. We will continue to make every effort to provide you with the most durable, long lasting pool package available.

In order for your warranties to be in effect please sign all acknowledgement / warranty cards provided and return them to the address listed on each card.

**~~IMPORTANT~~**

**BE SURE TO READ AND UNDERSTAND THE ENTIRE MANUAL  
PRIOR TO BEGINNING YOUR CRESTWOOD POOL  
INSTALLATION**

**HOMEOWNERS RESPONSIBILITY CHECKLIST**

**IMPORTANT:** IT IS **REQUIRED BY LAW** TO CALL THE LOCAL **UNDERGROUND UTILITIES LOCATING SERVICE** PRIOR TO ANY EXCAVATING. THEY WILL LOCATE AND MARK BURIED GAS, ELECTRIC, TV, PHONE etc. LINES. ( *Failure to do this is not only dangerous, you will have to pay for the repair of any damaged utility lines* )

**UPON RECEIPT OF POOL, CHECK PACKING LIST FOR SPECIFIC COMPONENTS  
OBTAIN A BUILDING PERMIT IF REQUIRED. CHECK THE FOLLOWING:**

- 1. LOCAL BUILDING AND ZONING REQUIREMENTS**
- 2. ELECTRICAL & BONDING REQUIREMENTS**
- 3. FENCING REQUIREMENTS**
- 4. BACKWASH ( *Waste* ) REQUIREMENTS**
- 5. HAVE PROPER TOOLS AVAILABLE. ( *See List Page 4* )**
- 6. OBTAIN INSTALLATION MATERIALS NOT SUPPLIED WITH YOUR POOL PACKAGE ( *Sand, Concrete, Rebar, Duct Tape, Etc. See Chart Below & Page 4* )**

**APPROXIMATE MATERIALS REQUIRED**

<b>POOL SIZE</b>	<b>SAND</b>	<b>CONCRETE REQUIREMENTS</b>	<b>3/8" REBAR REQUIREMENTS</b>
<b>12'X 24'</b>	<b>3 TONS</b>	<b>4 CUBIC YARDS</b>	<b>400'</b>
<b>15'X 30'</b>	<b>4.5 TONS</b>	<b>4.5 CUBIC YARDS</b>	<b>450'</b>
<b>18'X 33'</b>	<b>6 TONS</b>	<b>5 CUBIC YARDS</b>	<b>500'</b>

**Please Note:**

- **Concrete and Sand Requirements are Estimates Only. Varying depths of grade will necessitate adjustments to these quantities. Always order 1/2 to 3/4 yards more concrete than the chart shows ( *plus amount required if a filtration pad will be poured* ).**
- **3500 # Concrete ( Minimum ).**
- **We recommend "Fine - Washed Sand" free of any stones or sharp objects.**

# TOOLS REQUIRED

12 - 3/8" DIAM. METAL STAKES FOR LAYOUT  
CONCRETE FORMS or MASONITE & WOOD STAKES  
TRANSIT ( *Available at Local Tool Rental Stores* )  
HACK SAW or WOOD SAW  
TAPE MEASURES ( *50' Flexible Steel* )  
ROUND END MASON TROWELS, 12" TO 14"  
CORDLESS or ELECT. PHILLIPS SCREWDRIVER  
ELECTRIC DRILL ( *With Hammer Drill Option* )  
9/16" and 3/4" SOCKET & RATCHET  
3/4" WRENCH or RATCHET WRENCH  
15/16" WRENCH or RATCHET WRENCH  
3/8" MASONARY DRILL BIT  
1/2" MASONARY DRILL BIT  
SPRAY ADHESIVE  
WHEEL BARROW ( *Optional* )  
CONCRETE TOOLS: STEEL TROWELS, EDGER, BROOM ( *Optional* )  
SPECIAL BRACING TOOL ( *Available From Dealer* ) or 3 – 2" x 4" x 8' BOARDS

DUCT TAPE

SHOP VAC

LEVEL

RAZOR KNIFE

GARDEN RAKE

SHOVEL

PICK or MATTOCK

WISE GRIPS

1/8" DRILL BIT

3/16" DRILL BIT

3/8" DRILL BIT

2' SQUARE

STRING LINE

CHALK LINE

NAILS or SCREWS

**NOTE:** CUT THE FOLLOWING LENGTHS FROM EACH 2" x 4" x 8' BOARD FOR STEP #6 :

1 – 12" SUPPORT BLOCK

1 - 5' BRACE

1 - 2' STAKE

**AFTER DETERMINING THE BEST POSSIBLE LOCATION FOR YOUR POOL BASED ON PROPERTY LINES, SEPTIC TANK, OVERHEAD POWER LINES, GROUND SLOPE ETC..... YOU ARE READY TO BEGIN GROUND PREPARATION.**

**IMPORTANT: THE POOL CAN NOT BE BACKFILLED. THERE MUST BE PROPER DRAINAGE TO KEEP WATER AWAY FROM THE POOL.**

**THE WARRANTY/GUARANTEES IS VOID IF THE POOL IS BACKFILLED OR IMPROPER DRAINAGE EXISTS.**

### **STEP #1**

Using the "A" dimension from Drawing # 1, page 23, drive two 3/8" diameter steel stakes in the ground on the centerline of the pool. Locate an area, which will not interfere with excavation, and place offset stakes to enable relocation of center stakes after excavation is completed. Please Note: Offset stakes are extra stakes used during excavation that allow you to remove the center stakes, excavate the area, then measure from the offset stakes to reposition the center stakes necessary for continuing.

### **STEP #2**

Measure 3' towards the center from the first two stakes and drive two more 3/8" stakes. Using the "B" + "C" dimensions from Drawing # 1, page 23, mark out the dig area with lime, chalk, paint, etc.

### **STEP #3**

Remove all stakes except the offset stakes and level the entire dig area. Remove all sod, roots, etc. from the marked out area. Using a transit locate the Lowest spot and level the entire area to within 1/2" - 1" of the lowest spot. IMPORTANT: It is necessary to set the pool on solid ground, DO NOT build up low areas when leveling the pool area. Instead dig down to the level of the Lowest spot allowing the pool to rest on undisturbed earth. Please Note: If bottom is to be bowled out, this may require a special liner. Reset center stakes ( "A" ) measuring from the offset stakes placed in Step 1. IMPORTANT: It is necessary to make sure the center stakes are solid ( *No Flexing* ). All measurements made from these stakes are critical. Measuring from the center stakes ( "A" Dimension ) set forms to the " D ", " E " and " H " dimensions ( *for your size pool* ) listed in the Dimensions chart on Drawing # 2, page 24. When setting forms to grade, the outside forms should be 1/8" to the foot lower than the inside forms to allow any water ( *rain or splash over* ) to run away from the pool. Example: On the straight walls of oval pools, which are 3' wide, the outside form will be 3/8" lower than the inside form. Please Note: Skimmer CAN NOT be located on a straight wall. Consideration should be given to the placement of the filtration system. If it is desired, the concrete pad may be extended or a separate pad ( 3' x 4' min. ) can be formed and poured to accommodate the filtration system ( *most states require a Minimum of 5' from water edge* ). After forms have been set, hand dig a 1' wide x 1' deep ditch from top of forms on each straight wall ( Refer to Section B-B, Drawing # 3, page 25 ). Set forms to proper grade, concrete will be poured to the top of the forms, therefore forms must be level to within 1/8".

#### STEP #4

Using the "G" and "F" dimension on Drawing # 2, page 24, measure out towards the sides of the pool and drive a 3/8" stake at each *Intersecting Point* where the " G " and " F " dimensions meet

( 2 on each side of pool ). From each of these *Intersecting Points* measure towards the Outside forms 3 1/2" and drive a 3/8" x 18" rebar set stake. Again from the Original Intersecting Points, measure towards the Outside forms 2'- 5 1/2" and drive a 3/8" x 12" rebar set stake ( Refer to Figure 4-1 ). Drive stakes in so they are 2" below the top of the forms ( Refer to Figure 4-2 ). Repeat this procedure for each side of the pool. Tie a string between the back two sets of set stakes, 2 1/2" below top of forms. Drive 18" long -front ( Inside ) and 12" long- rear ( Outside ) stakes down to the string level, every 18" along the string lines. (Refer to Figure 4-1). These dimensions MUST be followed so steel will not interfere when installing the wedge anchors in STEP #5, page 7. Drive 3/8" x 12" stakes around the radius ends every 2' - 3', 2 -1/2" below the top of forms. Keep stakes 3"- 4" away from the inside and outside forms ( Refer to Figure 4-3 ). Finish steel reinforcement ( Refer to Drawing # 3, page 25 ) using the vertical stakes to tie the horizontal and lateral steel 3" below top of the forms. Twenty-foot lengths of steel can easily be tied to the vertical stakes around the radius ends, starting on one side and continuing to the next stake ( Refer to Figure 4-3 ).

**IMPORTANT:** Be sure to follow local electrical codes prior to pouring footers to provide for electrical bonding or grounding for the filter, cables and metal supports. Usually a piece of rebar or grounding wire that is tied to the steel rebar reinforcement grid should be left extending out of the footer on the center of each straight wall, cable end location ( 3 ) and at the filter location.

Figure 4-1

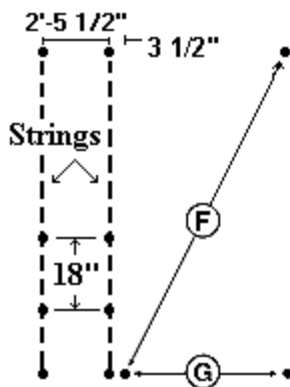

Figure 4-2

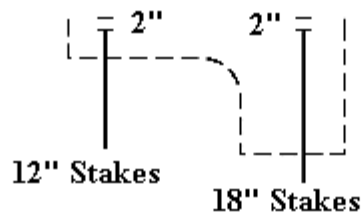
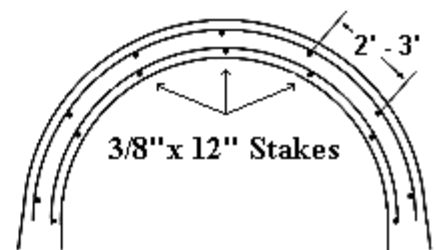

Figure 4-3



## STEP #5

Pour and finish the concrete ( *It is recommended to use an edging tool around the inside and outside perimeter of the forms* ). After concrete has set for 1 day you may continue.

### Please Note:

- The pool **MUST NOT** be filled with water until concrete has cured for a Minimum of 7 days. The pool may be completed prior to the 7 days, but can only be filled 1' Maximum to set the liner. The pool may be filled after the 7-day curing period.

Using the “G” & “F” dimensions on Drawing # 2, page 24, mark the concrete at each intersecting point ( *2 points on each side of pool* ). After marking the points on both sides of the pool it is necessary to measure across from point to point to make sure they are properly set ( Refer to the

“ I ” dimension on Drawing # 2, page 24 ). Snap a chalk line between the marks. There are 2 types of supports supplied with the pool kit, Bottom Wall Supports and Mid Wall Supports. Bottom Wall Supports have 2 Large holes in one leg of the angle iron and 6 Small holes in the other leg. The Large holes are used for the wedge anchors. The Small holes are used during erection of the straight walls ( Refer to Figure 5 -1 ). Mid Wall Supports have 2 - 3/8” holes in one leg of the angle iron and 2 - 3/8” & 4 - 1/4” holes in the other leg ( Refer to Figure 5-2 ). The Mid Wall Supports will be used in STEP # 11 after the entire pool wall has been erected. Place the Inside vertical leg of the Bottom Wall Supports on the chalk line with the edges touching each other ( *4 Bottom Wall Supports for 12' x 24' pool, Refer to Drawing # 5, page 27 > 5 Bottom Wall Supports for 15' x 30' and 18' x 33' pools, Refer to Drawing # 6, page 28* ). Using the holes in the Bottom Wall Support as a guide, drill a 1/2" hole into the concrete 4 1/2" deep. Remove the Bottom Wall Support and vacuum out holes. Insert a 1/2" wedge anchor into the holes and lightly tap with a hammer. Place the Bottom Wall Support over the wedge anchor. Place a 3" or 4" Strap over the wedge anchor and Bottom Wall Support ( Refer to Drawing # 4, page 26 and Drawing # 5, page 27 for 12' x 24' or Drawing # 4, page 26 and Drawing # 6, page 28 for 15' x 30' and 18' x 33' ). Install a washer and nut on anchor. Thread nut on anchor until it Just exposes the unthreaded portion at the top of the anchor. Tap anchor into concrete until the washer and nut are flat against the Strap. Place the 2' Square against the Bottom Wall Support and the 3" or 4" Strap. Make sure the Strap is square to the Bottom Wall Support then tighten the nut. **IMPORTANT:** *Make sure to tighten nuts to Approximately 50 Ft. / Lbs. Torque.* Repeat this procedure for all the holes in the Bottom Wall Supports ( *2 per support* ) on both straight walls.

Figure 5-1

Bottom Wall Support

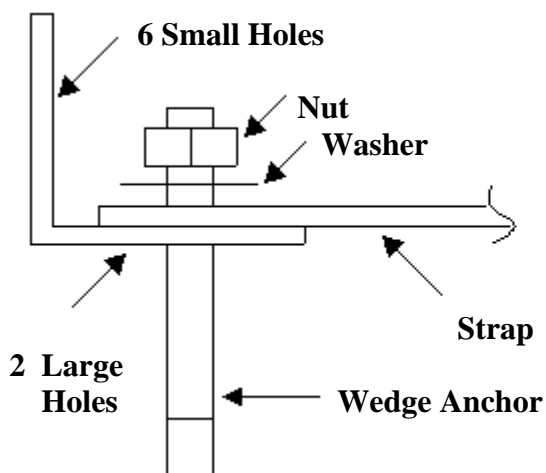
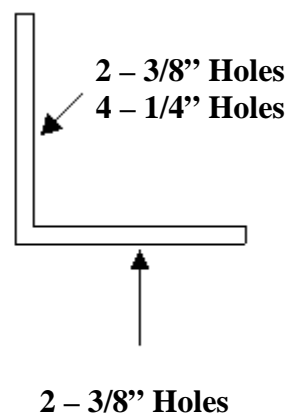

Figure 5-2

Mid Wall Support



**STEP #6**     **IMPORTANT:** 1. The sand Must be tamped where it meets the Concrete Footing to avoid /minimize settling of the sand. It is best to spread the sand in 2"- 3" lifts and tamp each lift with a Plate Tamper until reaching the Top of the concrete. It is best to tamp the entire pool bottom. Tamping the sand prior to erecting the walls will allow easy access for getting the Tamper in and out of the pool. 2. There is a top and bottom to each individual board. It is Necessary that the first board be examined to insure proper placement. If properly placed, the Bottom Groove will measure 6" from the Bottom of the board. Boards must be placed so the Grooved Side is facing Outward and the Smooth Side is facing Inward. It is necessary to inspect and use the straightest 2"x 8" Standard Boards and 2"x 4" Filler Boards for erecting the straight walls.

To begin erecting the pool, it is Necessary to start on the straight walls. Follow the instructions below and the Board Pattern outlined on page 9 "Exactly" to be sure all bolts and screws will fall close to the center of the boards and not on the board joints. Standing Outside the pool wall and starting at the Left Side of the Bottom Wall Supports align the Inside Edge ( *water side* ) of a 2"x 8" Standard Board with the edge of the Bottom Wall Support ( Refer to Figure 6-1 ). **Please Note:** The following procedure MUST be followed when installing the Dual Fiber Optic Lighting System: 1. Determine which side of the pool the lights will be placed based on personal preference, Walk-In-Stairs, decking, position of pool to house, etc. 2. The first board placed will be a Light Board. 3. Continue placing boards as per the normal instructions until reaching the position where the last board of the straight wall will be. 4. Place another Light Board.

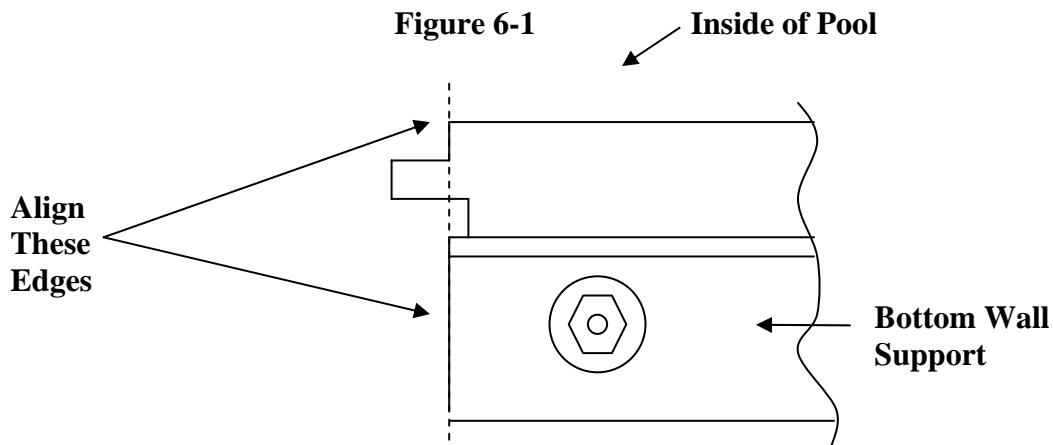

Place another 2"x 8" Standard Board against the first board. Check with the level to make sure the boards are plumb in all directions - in , out and side to side. Using the First hole on the Left side in the Bottom Wall Support as a guide , drill a 1/4" through the wood wall. From the Inside of the pool, insert a 1/4" x 2" Carriage Bolt through the wood wall and Bottom Wall Support. Place a washer and nut on the Carriage Bolt and tighten. Refer to Figure 6-1 & 6-2.

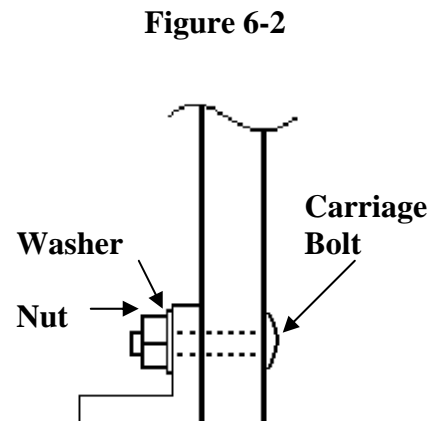
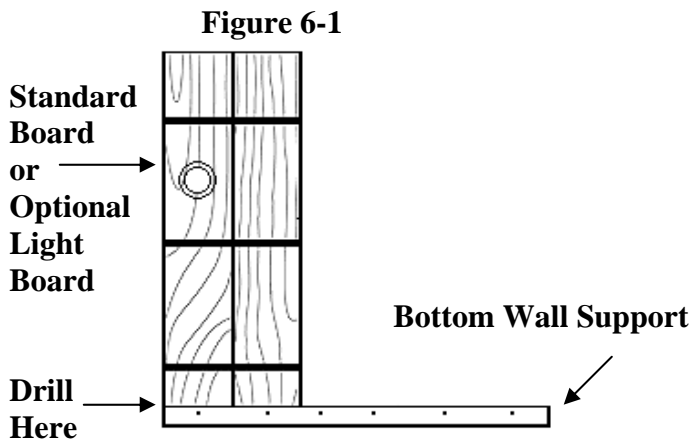

**STEP #6 continued**

Place a 2"x 4" Filler Board next, then 3 more 2"x 8" Standard Boards ( Refer to Figure 6-4 ). ***IMPORTANT:*** This pattern of 2 - 2"x 8" Standard Boards, a 2"x 4" Filler Board, then 3 more 2"x 8" Standard Boards will equal the length of one Bottom Wall Support. Continue with this pattern for the remaining straight wall. When placing boards keep boards as tight together as possible and be sure the Inside Edges are contacting each other from top to bottom with **NO** large gaps ( *1/8" or larger is unacceptable* ). Try switching a board to another location if the gap is too large. To keep individual boards from disengaging while setting up the wall, place straight coping sections on wall while erecting. This procedure **MUST** be followed for both sides of the pool.

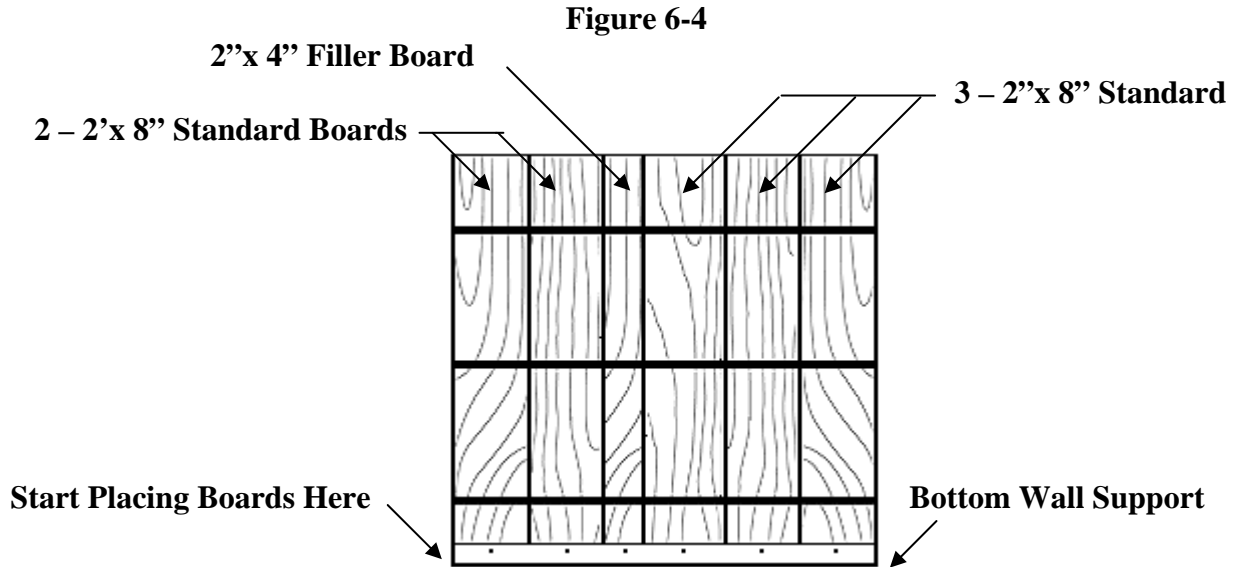

**STEP #7**

Measuring from the center stakes, ( "A" ) scribe a line for the radius ends of the wall. The dimension is 6'-3/4" for the 12' x 24', 7'- 6-3/4" for the 15' x 30', 9'-3/4" for the 18' x 33'. Working from the straight wall, continue placing 2"x 8" Standard Boards with the Inside Edge of the boards on the Scribe Line. Add sections of curved coping as necessary leaving a 1/2" gap between sections. Install a Coping Clip over each coping joint. Refer to Step #24, page 22 for Coping Clip Installation instructions. After placing every 10 - 20 boards check with the level to make sure boards are plumb ( Refer to Figure 7-1 ). Brace the wall every 8' - 10' when erecting the Radius ends of the pool. Due to the tendency that the wall leans out at the top while erecting the pool, wedge a board between the ground and the top cable groove ( Refer to Figure 7-2 ). This is easily accomplished by the following procedure ( 1 ) have one person check and hold the wall plumb ( 2 ) lean a board against the pool wall so the top rests about 1/4" above the top cable groove ( 3 ) push Inward on the top of the wall only enough so the board slides down and drops into the cable groove. Recheck with level and adjust if necessary.

**Figure 7-1**

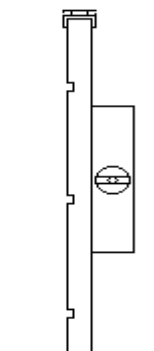

**Figure 7-2**

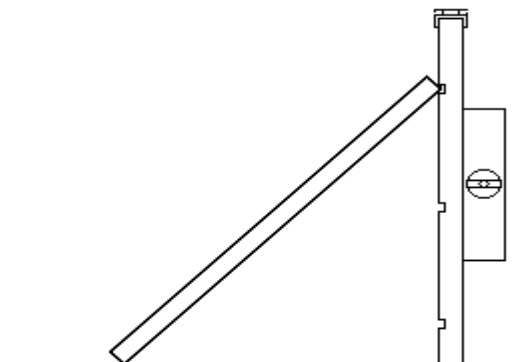

### STEP #7 continued

When the filtration area is reached, place the two 2" x 6" Skimmer Boards, which are Shorter, then the Standard Boards. Continue with Standard Boards for approximately 4' - 5' then install the Pre-Drilled Return board. There are 2 – 2"x 4" and 2 – 2"x 6" Filler boards supplied which may be used in combination with the standard boards to fill the final space on each radius end. Extra boards are included in the pool kit to compensate for shipping damage or unusable boards. It is necessary to install only the number of boards required to complete the radius ends of the pool.

### STEP #8

**DO NOT** cut the last piece of coping on both radius ends to the proper length, let it overlap the straight coping. After the entire pool wall is erected, measure the length of the pool making sure that the pool is 1" to 1-1/2" larger than the desired pool length ( Refer to Drawing # 1, Pool Size, page 23 ). Be sure to measure the pool length from the Inside Edge ( *Water Side* ) of the coping at the center of each radius. After installing and tightening the cables, the boards will mesh together tightly and the length measurement may be slightly larger than the desired finished dimension. ( *This is normal* )

### STEP #9

Before installing the cables, make sure there is still a 1/2" gap between the coping sections at each joint. Please Note:

- There are two different size cable assemblies provided. The Larger diameter cable MUST be installed in the Bottom cable groove. The smaller diameter cable will be used for the Middle and Top cable grooves.
- A small bead of the NEVER-SEEZ compound provided in the kit MUST be applied to all threaded ends on cables.
- Lugs **MUST NOT** be installed directly over each other or on the straight walls. Stagger lugs approximately one-third of pool perimeter.

After the walls are totally erected, install the Middle cable. To install a cable, place one threaded end through the lug making sure the stud is directed away from the pool wall. Slide the lug over the cable exposing all threads. Apply NEVER-SEEZ to threads. Install the washer and nut. Slide the lug back over the thread ( Refer to Figure 9-1 ).

Figure 9-1

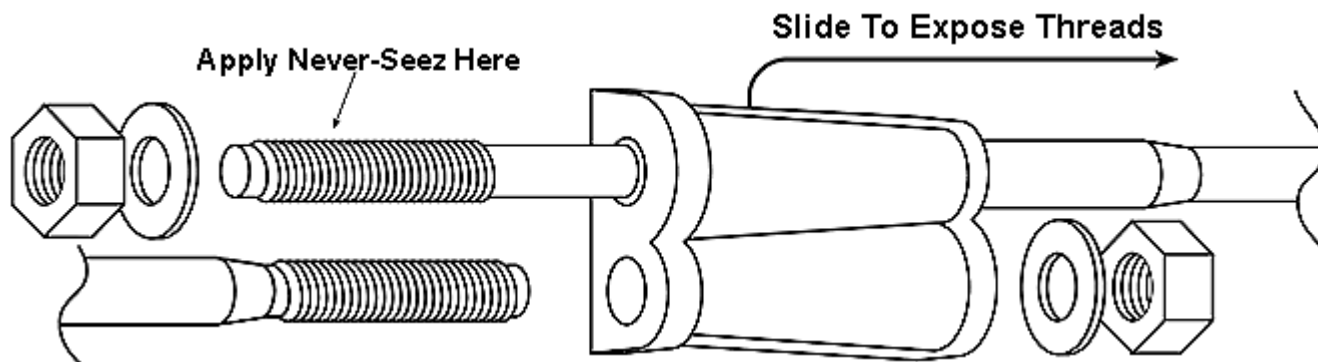

It is easier to install cables with two people. One person should hold the lug aligned in the groove, while the second person unwinds the cable and inserts it into the groove keeping constant tension on the cable. When the Starting point is reached, make sure the loose threaded end of the cable protrudes past the lug approximately 1" so that the washer and nut can be installed. If the washer and nut can be started, apply NEVER-SEEZ to threads, insert through lug, install washer and nut. If the washer and nut **Can Not** be installed, the Cable-Tensioning Tool ( *available from your dealer* ) will need to be used as shown in Figure 9-2.

### STEP #9 continued

Install the Cable-Tensioning Tool by inserting the stud through lug as shown in Figure 9-2. Place the nut on the stud. Insert cable end through tube and thread nut on as far as possible. Apply pressure in direction shown. While tension is being applied, another person should walk around pool lightly kicking the Bottom of pool wall inward while shaking the Top on the Radius Ends Only. This will engage the boards making it possible to install a washer and nut on the threaded end. Make sure cable end is at least 1" past the end of the lug so that there is enough slack to start the nut and washer. Remove the Cable-Tensioning Tool while keeping the cable tight ( *this is best accomplished by having a person push the cable into the cable groove on either side of the person( s ) removing the Tensioning Tool* ); apply Never-Seez, washer and nut as stated above. If the cable end still will **Not** protrude 1" past the lug a board must be taken out. To remove a board keep slight tension on Tensioning Tool, then remove a section of coping ( **NOT** in the area where Tensioning Tool is being used ). Remove a board from the center where the coping was removed and install a smaller filler or combination of boards, which will equal the amount of cable needed to let the end protrude 1" past the lug. Replace coping section and repeat the above procedure for the Cable Tensioning Tool.

Figure 9-2

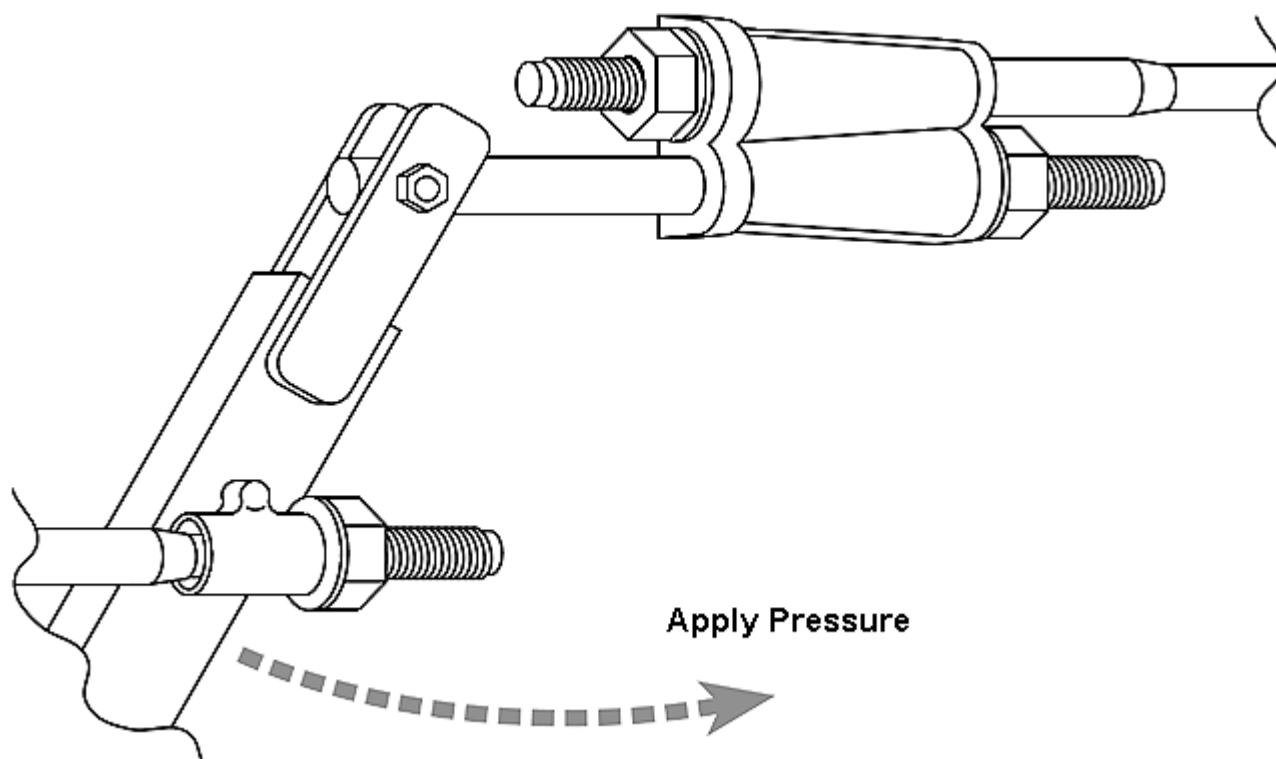

Tighten the Middle cable until all of the slack is out of the cable ( *when tightening the nut, you will have to hold the opposite end of the stud with vise grips* ). The wooden bracing can now be removed. While tightening the cables, make sure there is a 1/2" gap between the coping sections at each joint. As the cables are tightened the gaps will close and it may be necessary to slide the coping sections apart or trim 1 piece of coping to maintain the proper gap. Maintaining the proper gap will allow the boards to engage tightly. After Middle cable becomes snug, the straight wall must be attached to the Bottom Wall Support using the 1/4" x 2" Carriage bolts and the #12 x 1-1/2' S.S. self-tapping screws supplied ( Refer to Figure 9-3, page 12 ).

**STEP #9 continued**

Check the wall with a level to make sure the wall is plumb. Using the Outside 2 holes in the Bottom Wall Support as a guide, drill a 1/4" through the wood wall. From the Inside of the pool, insert a 1/4" x 2" Carriage Bolt through the wood wall and Bottom Wall Support. Place a washer and nut on the Carriage Bolt and tighten. Refer to Figure 9-3 & 9-4.

**IMPORTANT:** Pre-drilling of the 4 Center holes with a 1/8" drill bit is necessary to avoid wood splitting. The screws pass through the angle iron and thread into the pool wall. A screw **MUST** be installed in the 4 Center holes in the angle iron (Refer to Figure 9-3 & 9-5). Failure to install the Carriage Bolts and Screws as described can result in the uplifting of the entire wall when the pool is filled with water. The bolts and screws will also keep the pool wall from collapsing and falling off the footer when installing the remaining cables and tightening all cables.

Figure 9-3  
9-5

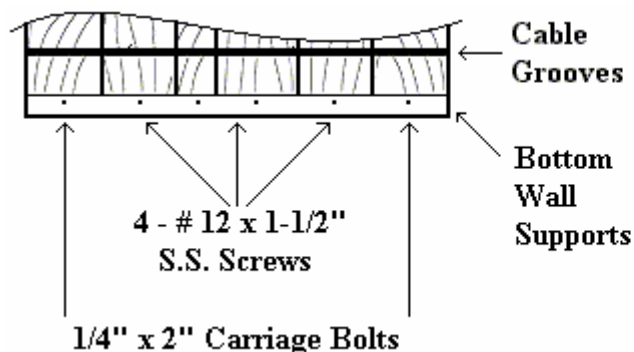
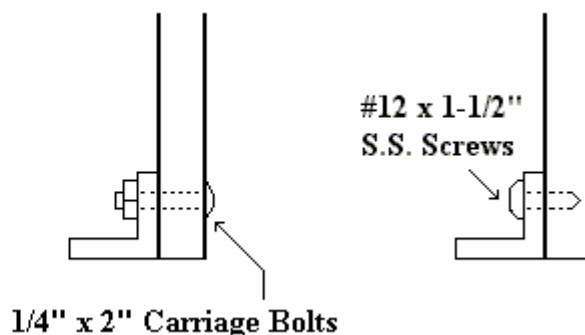

Figure 9-4



Figure

Install the Bottom ( *Large* ) and Top ( *Small* ) cables, tighten the three cables alternately, place a level on the boards around the radius ends and adjust the tension to plumb the boards. Tighten the cables as tight as reasonably possible. The pool wall will become very rigid when the cables are properly tightened ( Refer to Figure 9-5 ). **IMPORTANT:** Make sure all cables are tight! Insufficient tightening of the cables can cause a loose pool wall with excessive gaps between boards. Install the black caps on each threaded cable end.

Figure 9-5

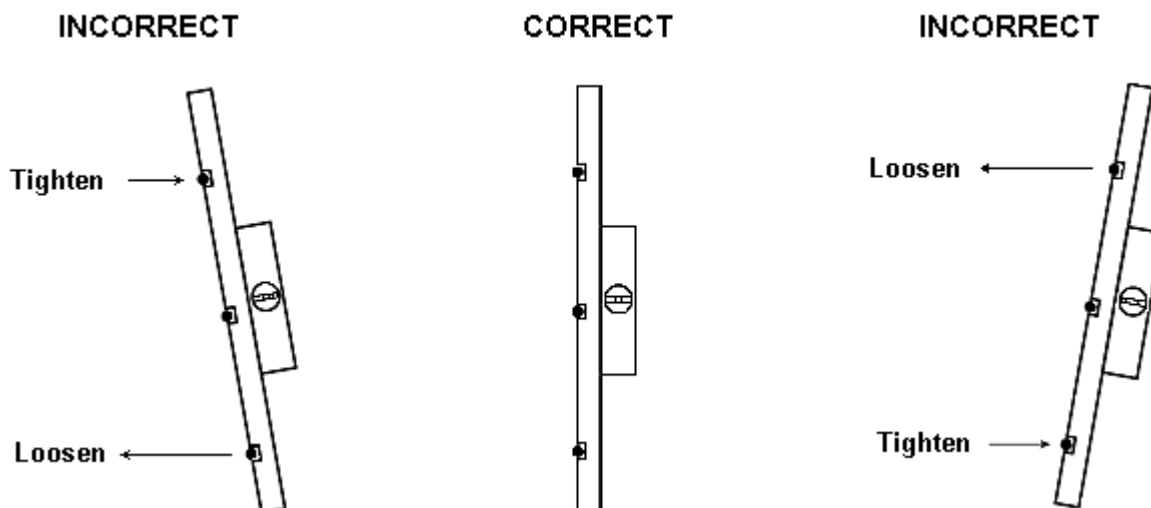

## STEP 10

After tightening the cables, be sure that all coping joints are tight. It may be necessary to slide or trim the sections of coping so the joints Line Up with the board joints. Cut the overlapping piece of coping on each radius end so that it fits into place. Remove straight coping and install the S.S. Channels. The S.S. Channel is placed on top of the straight section of pool wall. Align the end of the S.S. Channel with the end of the straight wall. Use a rubber mallet to make sure Channel is fully seated on wood. Replace straight coping making sure Liner Receptor Groove is on Inside of pool.

**Please Note:** It is possible to place the straight coping pieces on the pool incorrectly. This will result in placing the cover groove on the inside of the pool and the liner groove on the outside of the pool. Pay close attention to the proper orientation of the straight coping pieces ( Refer to Figure 10 ). If not sure of the proper position, look at the curved sections of coping.

Figure 10

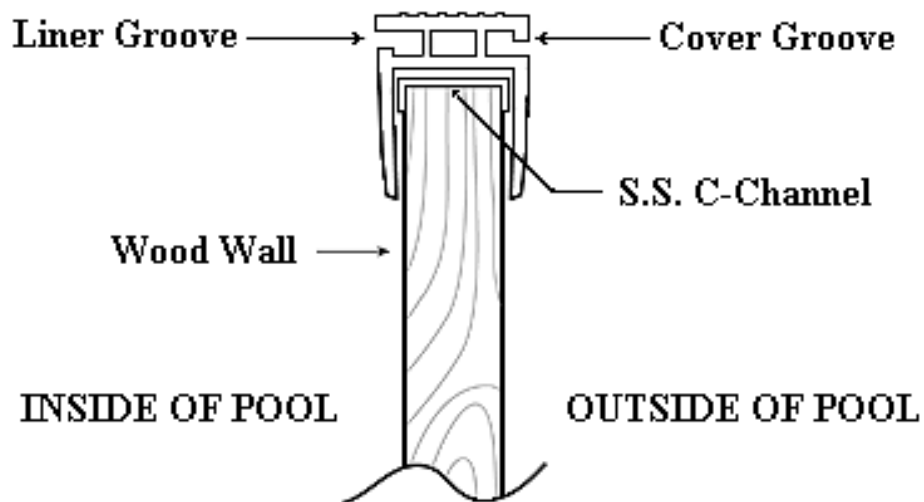

## STEP #11

With a level, check to make sure the entire straight wall is plumb, brace if necessary. Measure 2'- 5" up from the concrete and mark the wood wall on each end of the straight wall ( Refer to Drawing # 4, page 26 ). Snap a chalk line on the wall between the marks. Hold a Mid Wall Support against the wall so the Top of the angle is on the chalk line and the Outside Edge is aligned vertically with the Outside Edge of the Bottom Wall Support ( Refer to Figure 11-1 ). Using the 2 holes in the Mid Wall Support as a guide, drill a 3/8" hole through the wood wall. From the Inside of the pool, insert a 3/8" x 2" carriage bolt through the wood wall and Mid Wall Support. Place a washer and nut on the carriage bolts and tighten so as to draw the carriage bolt head in flush with the wall ( Refer to Figure 11-2 ). Align the next Mid Wall Support with the existing Mid Wall Support so the edges are touching and the Top of the angle is on the chalk line. Repeat the above drilling and bolting procedure. Continue across the entire straight wall (4 Mid Wall Supports for 12' x 24' pool, 5 Mid Wall Supports for the 15'x 30' and 18'x 33' pools ). Refer to Drawing # 5, page 27 for 12' x 24' or Drawing # 6, page 28 for 15' x 30' and 18' x 33'.

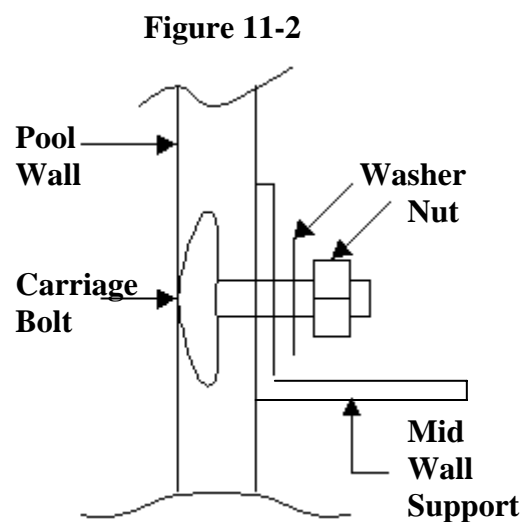
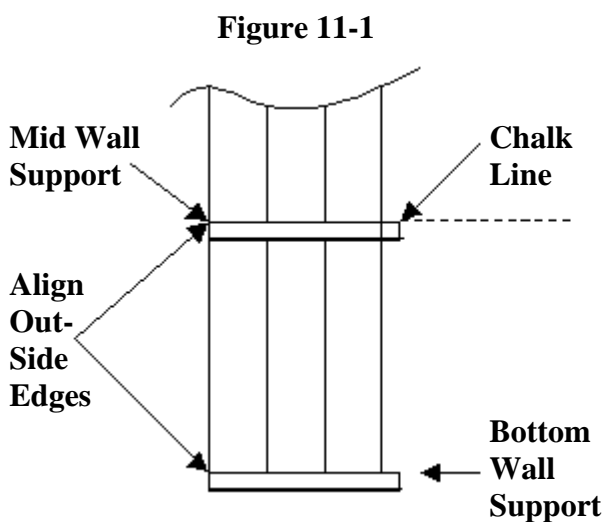

Place a 3" or 4" Brace between the corresponding 3" or 4" Strap and Mid Wall Support ( Refer to Drawing # 4, page 26 and Drawing # 5, page 27 for 12' x 24' or Drawing #4, page 26 and Drawing # 6, page 28 for 15' x 30' and 18' x 33' ). Using the 3/8" x 1" Hex Head bolts and washers Loosely bolt the Braces to the Mid Wall Supports and Straps. Tighten the bolt(s) holding the Braces to the Mid Wall Support. Check if each end of the straight wall is plumb then tighten the bolts holding the 3" Braces to the Straps. Attach or hold a string line along the top of the entire straight wall. Adjust the wall in or out to touch the string line then tighten the bolts holding the 4" Braces to the Straps. Repeat STEP #11 for the other straight wall.

### STEP #12

There are 4 Curved Angle Supports provided with the pool kit. Set one of the supports against the pool wall starting at the Bottom Wall Support and continuing around the radius ( Refer to Figure 12 ). Move the wall in or out so the wall has maximum contact with the support. Using the hole in the support closest to the straight wall as a guide, Drill a 3/8" hole in the concrete 2 1/2" deep. Using one of the S.S. Wedge Anchors supplied, insert anchor through support into concrete. Place washer over anchor and thread nut on anchor so the top of the nut is just below the top of the anchor. Drive anchor into concrete with a hammer until the nut contacts the washer and support. Using the hole in the opposite end of the angle support, drill concrete and insert anchor as above. Installing the anchors in this sequence will keep the Curved Angle Support tight to the pool wall and not allow misalignment of holes. Tighten nuts. Repeat this procedure for the remaining 3 Curved Angle Supports ( *one extending from each straight wall* ).

Figure 12

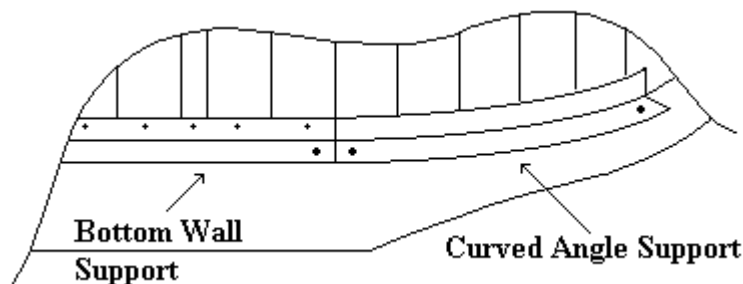

### STEP #13

**Support Cover Installation:** Place Support Cover against wall with flex joint up and screw guide out. Align the edge of the Support Cover with the edge of the Mid Wall Support ( Refer to Figure 13-1 & Figure 13-2 ). For each length of Support Cover, drill ( 3 ) 3/16" holes through the screw guide ( *one in center and one on each end* ) and install ( 3 ) #10 x 3/4" S.S. Coping screws. Tighten screws so head just contacts support cover. **Do NOT Over-Tighten** screws or cracking may occur.

Figure 13-1

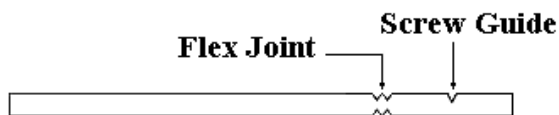

SIDE VIEW - SUPPORT COVER

Figure 13-2

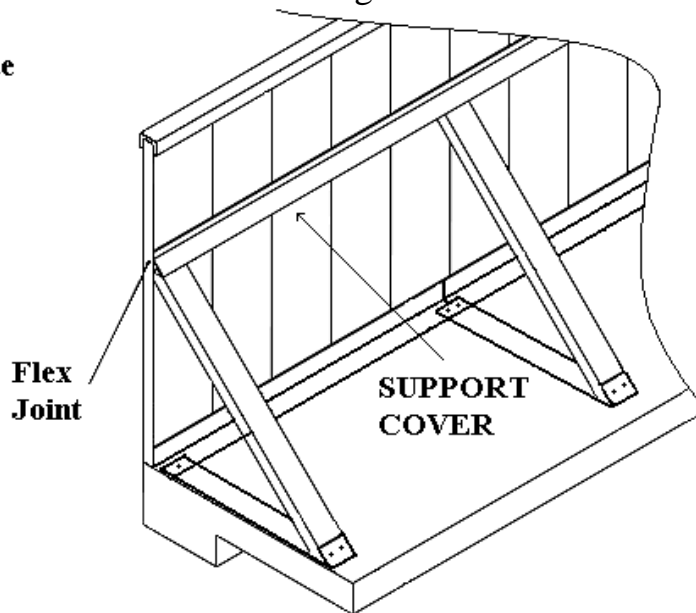

## STEP #14

Remove the section of coping where the skimmer will be installed. Attach the Skimmer Mounting Brackets to the skimmer flange using ( 6 ) #10 x 3/4" S.S. Coping screws ( 3 on each side ). The screws will pass through the holes in the skimmer flange and thread into the Pre-Punched holes in the bracket ( Refer to Figure 14-1 ). Place the skimmer over the two short boards. Level the skimmer body before mounting it to the pool ( *a non-level skimmer will be very noticeable when the pool is filled with water* ). Attach the brackets to the wall using 6 Coping screws ( 3 on each side ). The screws will pass through the Pre-Punched holes in the bracket and thread into the pool wall ( Refer to Figure 14-2 ). The skimmer filler board MUST be installed while replacing the section of coping. Install filler so the cut side faces up and down ( Refer to Figure 14-3 ).

Figure 14-1

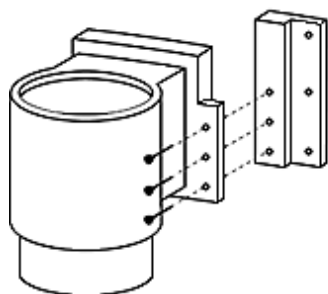

Figure 14-2

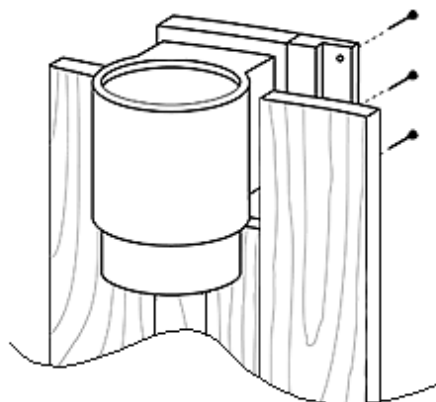
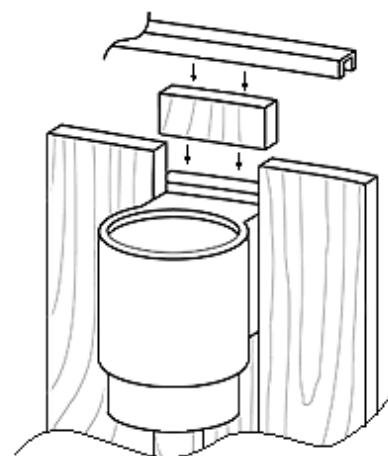

Figure 14-3



## Step #15

Standing Outside the pool, Pre-drill the coping ( **DO NOT** drill wood ) with a 3/16" drill bit.

Drill the first hole approximately 2 1/2" away from a coping joint then drill additional holes approximately every 2'. **DO NOT** drill a hole within 2 1/2" of each coping joint or it will interfere with the coping clips ( Refer to Figure 15-1, page 17 ). Hold a coping clip centered on the joint as a guide, then drill a hole about 3/8" to either side of the clip. Try to position each hole in the center of a board. When drilling the holes on the straight walls of the pool, position each hole no more than 1/2" up from the bottom edge of the coping. This is to prevent the hole from interfering with the S.S. Channel. After all holes are pre-drilled install a #10 x 3/4" S.S. Coping screw in each hole while holding the coping down against the top of the wood wall. **IMPORTANT:** Make sure coping is fully seated on the wood wall ( Refer to Figure 15-2, page 17 ). Tighten screws so screw head just contacts coping. **DO NOT** Over-Tighten the screws or cracking may occur.

**STEP #15 continued**

**Figure 15-1**

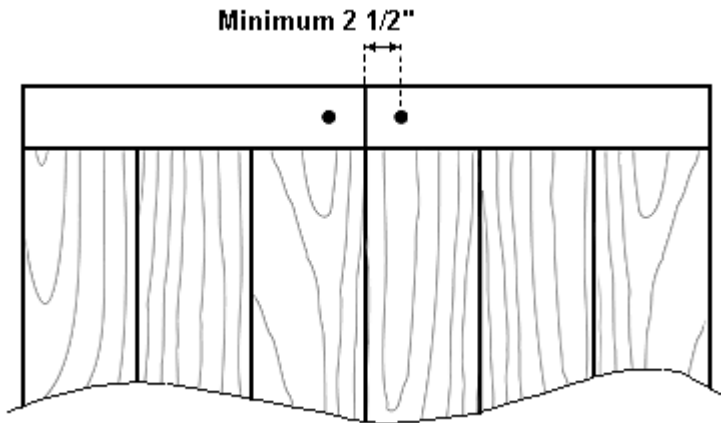

**Figure 15-2**

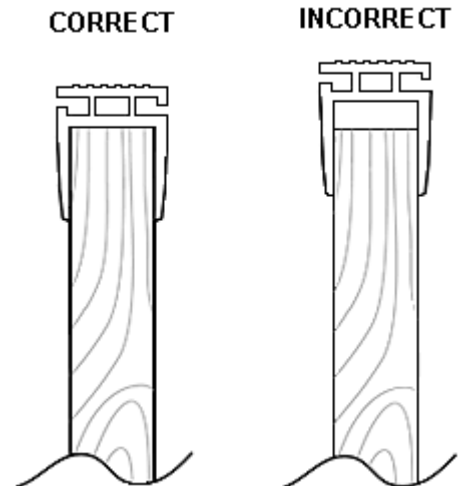

**STEP #16**

Cover any decayed knots (*holes*) or large imperfections on the Inside wall surface with duct tape or wood filler before installing wall foam. Place the wall foam inside the pool wall and begin unrolling and taping it to the coping with duct tape ( Refer to Figure 16-1 and 16-2 ). **Please Note:** If a vac will be used to remove wrinkles and insure a better liner fit as described in STEP #21, page 20, it is necessary to attach the foam to the bottom of the pool wall. Use spray adhesive or a 3/4\" roofing nail placed in each board for 4 - 6 feet to either side of where the vac will be placed so the vac will not pull the foam up from behind the sand cove. A good place to do this is between the skimmer and return fittings so you have a guide to where the foam is attached to the wall. Continue around perimeter of pool overlapping foam at the starting point. Cut through both layers of foam to get a matched joint, then tape the joint ( Refer to Figure 16-3 ). Spray adhesive is recommended around the entire perimeter of the pool to hold foam to wall.

**Figure 16-1**

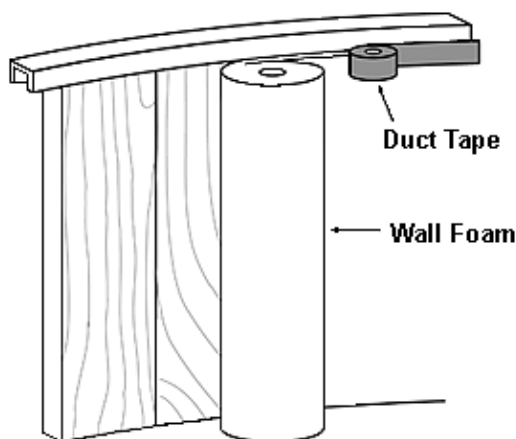

**Figure 16-2**

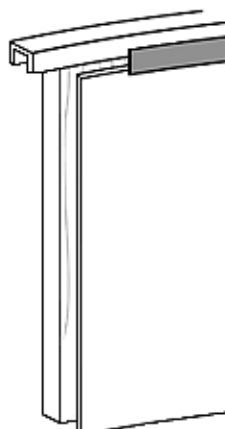

**Figure 16-3**

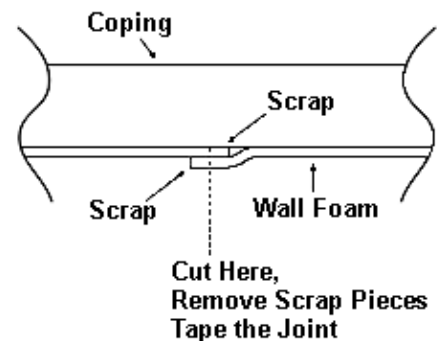

### STEP #17

The foam **MUST** be removed from where the Skimmer, Return Fitting / Light Fitting ( s ) will be installed. Using the Outside Edge of the Skimmer as a guide cut and remove the foam covering the Skimmer ( Refer to Figure 17-1 ). After removing the cut pieces of foam, tape the foam to the pool wall. Next install one ( 1 ) Skimmer Gasket directly to the face of the Skimmer using either tape or spray adhesive. Align all the holes in the Gasket with the Skimmer holes; be sure **NOT** to cover the holes with tape. Using the hole on the Inside of the pool as a guide cut and remove the foam covering the hole in the Return / Light Board ( s ) ( Refer to Figure 17-2 ). Please Note: If a Light is to be installed, proceed to STEP #23, page 21 and read the light installation information. Install a Return Fitting or Light Fitting by sliding the Fitting into the wall from the Inside of the pool. The foam will be sandwiched between the wood and the Fitting. Install the nut ( *Flats toward wood* ) as shown in Figure 17-3 and tighten. **HAND TIGHTEN ONLY.**

Figure 17-1

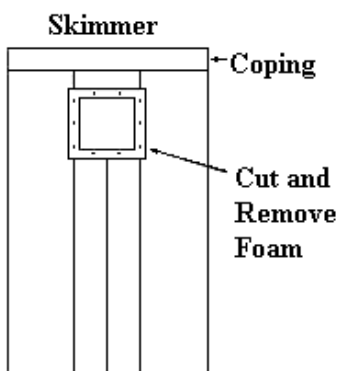

Figure 17-2

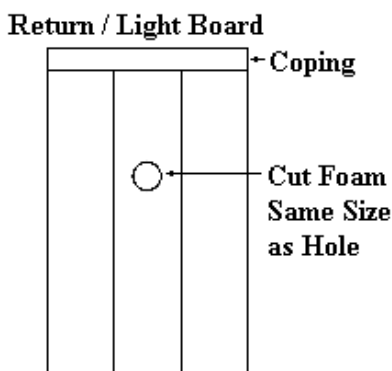
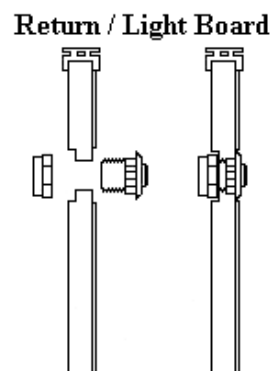

Figure 17-3



### STEP #18

Spread sand evenly around pool bottom with a rake and trowel it smooth. Sand should be a minimum of 2" thick and may have a small cove at the base of wall. The sand can be dampened to make it easier to work with ( Refer to Figure 18 ). **IMPORTANT:** Be sure to pack or tamp the sand at the cove area to reduce the chances of settling when the pool is filled with water.

Figure 18

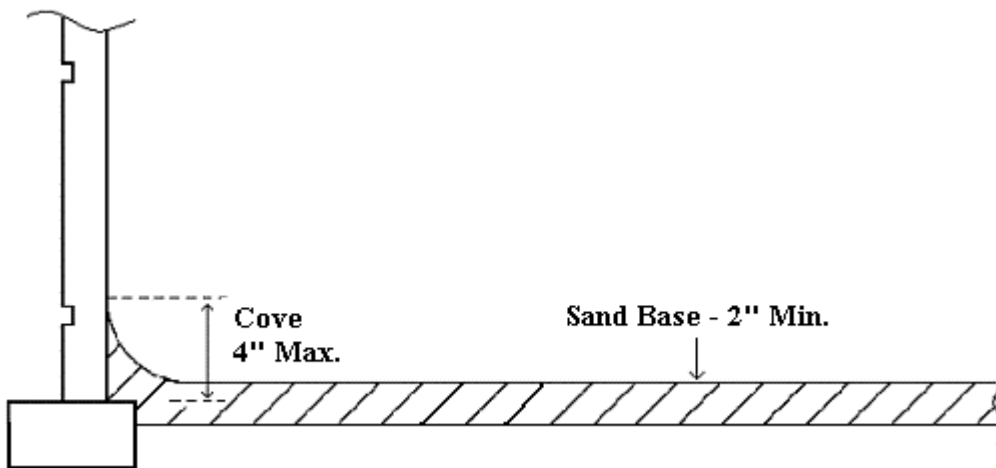

## STEP#19

Prior to installing liner, it is beneficial to open liner up to allow the material to relax and remove some of the package wrinkles. Make sure area where the liner will be opened is free of any objects that could damage the liner. Take notice how the liner is fan folded so you can refold it in the same manner prior to installing it into pool. Remove the coping clips ( Refer to STEP #24, page 22 ) and tape over the joints. Be careful not to tape over the liner track on the Inside Edge of the coping. To install your liner, it is best to have 3 or 4 people present. Make sure there are no objects that could damage the liner on the ground where the liner is to be opened. Place the liner as close to the pool as possible ( *position B* ) and unroll toward position A and C ( Refer to Figure 19-1 ). The liner is fan folded accordion style for ease of installation ( Refer to Figure 19-2 ).

Figure 19-1

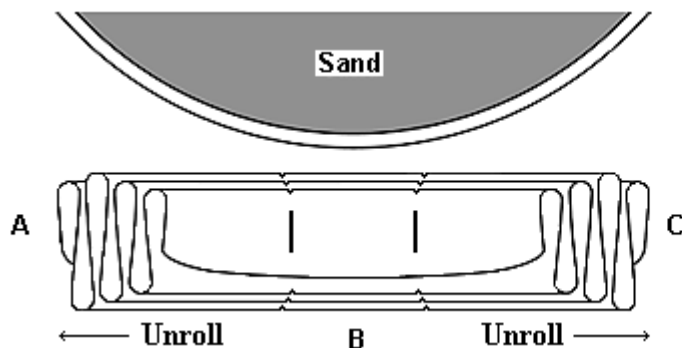
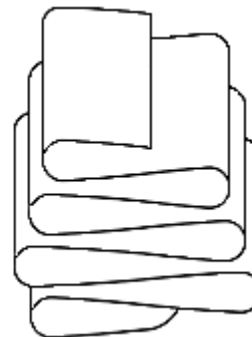

Figure 19-2



## STEP #20

Make sure the liner is positioned so the heavy tab ( *Bead Portion* ) can be inserted into the Inside Groove of the coping ( Refer to Figure 20-1 ). The people in positions A, B and C can now lift the entire liner up and over the pool wall. As the person in Position B starts inserting the bead into the inside groove, Persons A and C, can gradually walk around the pool allowing a small portion of the liner to unfold ( *one fold at a time* ) while taking special care not to drag the liner across the sand bottom ( Refer to Figure 20-2 ). Position B can continue inserting the bead around the perimeter of the pool until the liner bead is completely inserted into the groove. It may be necessary to go back to the starting position and slide the liner towards the area opposite the starting point. This will give you the amount of slack necessary too completely snap in liner.

Figure 20-1

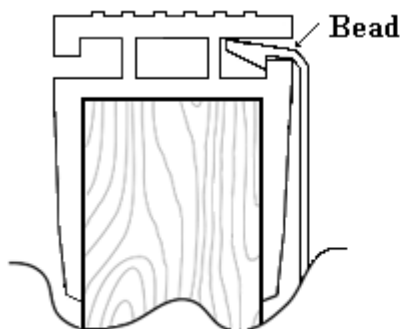
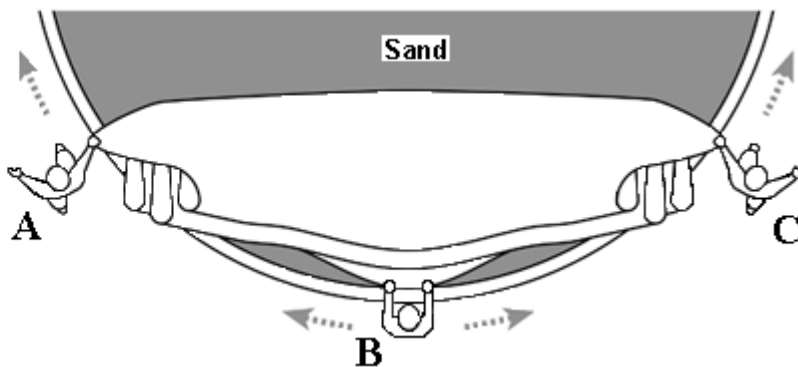

Figure 20-2



## STEP #21

To remove most of the wrinkles, reach down to the bottom of the pool wall and push the liner back against the wall or push the liner Outward with a broom ( **\*\* Make sure there are NO sharp protrusions on the broom** ). Be careful **NOT** to damage sand ( *cove* ) under liner. To remove any remaining wrinkles and to insure a perfect fit, a heavy-duty shop vac should be used. Take a small section, 8" – 12", of the liner out of the track and insert the vac hose 6" – 12" from the pool bottom. Tape around the vacuum hose, skimmer, return and light holes as well as all other possible air leak areas to ensure a good seal ( Refer to Figure 21 ). Turn the vac on and the wrinkles should disappear.

Figure 21

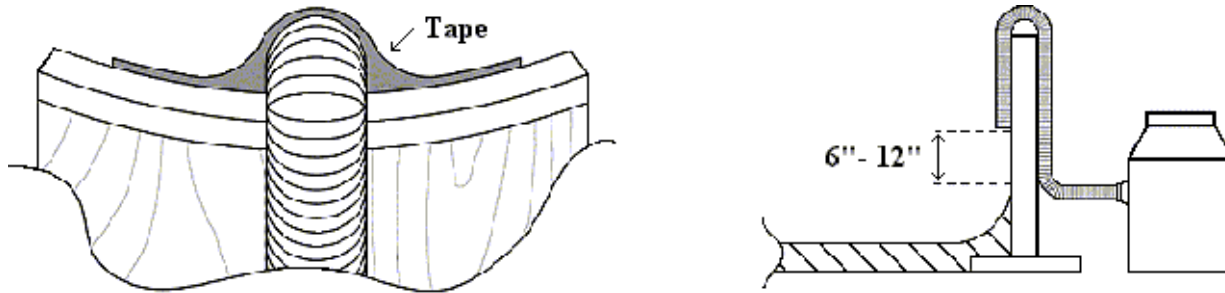

If all wrinkles are not removed by the vac, it may be necessary to work the wrinkles outward ( *toward wall* ) while water is filling. This is accomplished by lightly tapping the liner Outward with a broom at the base of the wall ( **\*\*Make sure there are NO sharp protrusions on the broom** ). Be careful not to damage sand ( *cove* ) under liner. It may be necessary to turn the vac off and reposition the liner to be able to work the wrinkles out. After the wrinkles have been worked out, continue filling the pool. If wrinkles still exist they may be worked out as the water is filling . **DO NOT** allow any wrinkles to be covered with water that will not be held out by the water pressure. Once the water is in; you will **NOT** be able to move the liner. Allow 3"- 4" of water to cover the entire bottom of the pool before turning off and removing the vacuum.

## STEP #22

**IMPORTANT:** Pool **CAN NOT** be filled with water until the concrete has cured for 7 days. After the concrete has cured for 7 days you may continue filling the pool until it is approximately 2" below the Return fitting and Light fitting if used. Attach the Return Face Plate by carefully locating the screw holes through the liner and screwing the Face Plate on uniformly and snugly. Repeat this procedure on the Skimmer when the water level is 2" below the Skimmer.

### Please Note:

- A Gasket **MUST** be placed between the Skimmer Face Plate and the liner. Continue filling the pool until two-thirds of the Skimmer Face Plate is covered with water.
- The liner **CAN NOT** be cut out from the center of the Return and Skimmer Face Plates until Face Plates and the Filtration System have been installed.

**Single Light:** Remove the Nut from the Light Fitting and slide it off Cable. Install the Cable and Fitting as described in STEP #17, page 18. Remove the Clear Lens from the Light Fitting ( *be careful not to scratch lens* ). \*\* Continue to build the pool through STEP #22, page 20. Using the Inside Edge of the Face Plate as a guide be Extremely careful and cut out the liner ( *with a razor* ) from the center ( Inside ) of the Light Face Plate(s). Thread the lens into the fitting. Snug the lens with Channel Lock Pliers gripping on the 2 Flats ( *it is best to remove the nut holding the Fitting into the wall and hold the fitting from turning by hand, a large pair of Channel Lock Pliers or a Strap Wrench* ). **DO NOT Over-Tighten**. For Single Light installation only, loosen the Acorn Nut on the Illuminator Box Cover and insert the Aluminum Cable End into the Heyco Connector. Make sure there is 1/4"– 1/2" gap between the Cable End and the internal Housing then tighten the Acorn Nut ( Refer to Figure 25-1 ). Mount the Illuminator Box on a Post or on the Deck. **Please Note:** The Illuminator Box **MUST** be a Min. of 5' from the pool wall. Follow all other instructions supplied with the light.

**Dual Light:** Remove the Clear Lens from both Light Fittings ( *be careful not to scratch lens* ) Remove the Acorn Nut from the end of the Fiber Optic Cable and slide the Heyco Connector & Clear Washer off. Pull the Cable out of the Fitting. Install the Fittings as described in STEP #17, page 18. \*\*\* Feed the Cable through the Fitting from the Outside of the pool until it extends 1' – 2' into the pool. Slide the Heyco Connector & Clear Washer over the Cable. Install the Acorn Nut and align the End of the Fiber Optic Cable so it extends 1/32" Max. past the Acorn Nut then tighten until it is secure on the Cable (Refer to Figure 25-2) **DO NOT Over-Tighten**. Push the Cable and Connector into the Fitting until the Clear Washer contacts the Rib in the center. Continue from the \*\* in the Single Light instructions above.

**Cable Protection Option:** Install the Light Fitting(s) in the wall as described in Dual Light above. Thread a Male Adapter into the Light Fitting. Tighten by hand or with a pair of large slip-joint pliers. **DO NOT Over-Tighten**. Measure and cut pieces of 1-1/2" PVC Pipe ( *with necessary elbows etc.* ) to fit between the light and the Illuminator Box. A typical plumbing layout is shown in Figure 25-3 ( *this may be altered based on finished grade and/or deck requirements* ). Place a piece of string or light wire in the pool and feed it through the Light Fitting in the wall, PVC pipe and fittings while you assemble them working from the pool to the Illuminator Box ( *the string or wire will be used to pull the Fiber Optic Cable through the plumbing from the Illuminator Box to the pool* ). It is **NOT** necessary to glue the joints. The plumbing is to protect the Fiber Optic Cable from potential damage and is **NOT** open to the water. Tape and/or tie the string or wire to the Fiber Optic Cable. Using the string or wire, pull and feed the Cable through the plumbing until it extends 1' – 2' into the pool. Remove the string or wire. Continue from the \*\*\* in the Dual Light instructions above. Silicone around Fiber Optic Cable and 1/2" x 1-1/2" Reducing Bushing when installation is finished to keep water and insects from entering.

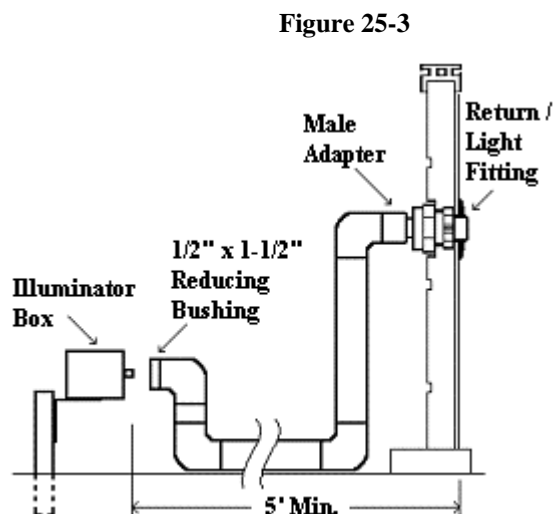
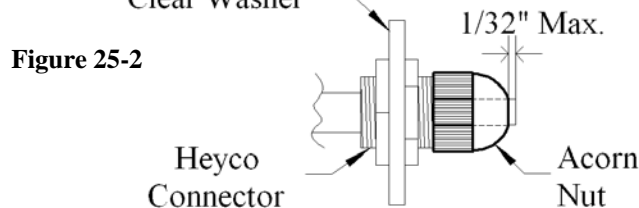
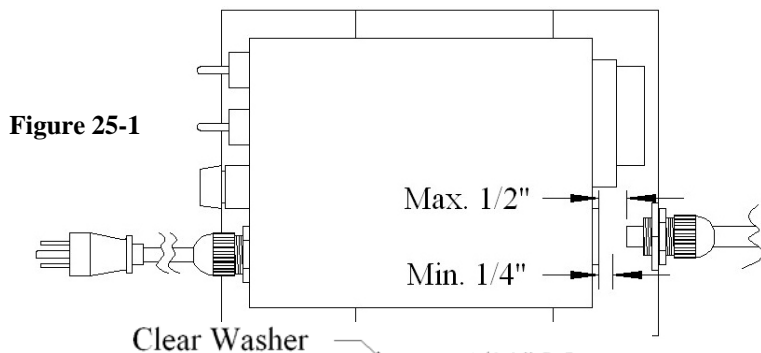

#### STEP #24

Place a coping clip over all coping joints ( Refer to Figure 24-1 ). To install a coping clip insert the inside lip into the liner groove of the coping ( 1 ). Pull outward on the outside leg of the coping clip ( 2 ) until the locking tab will clear the cover groove. Push downward to snap clip into place ( 3 )

( Refer to Figure 24-2 ). To remove a coping clip, pull outward on the outside leg to release the locking tab from cover groove ( 2 ), lift up outside leg and push inward.

Figure 24-1

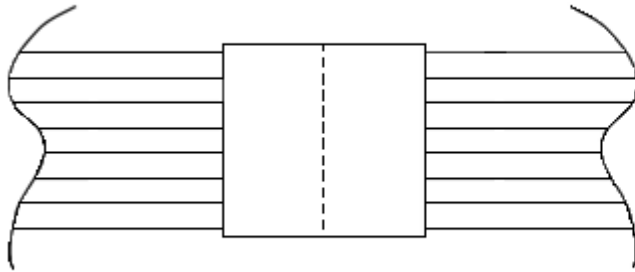
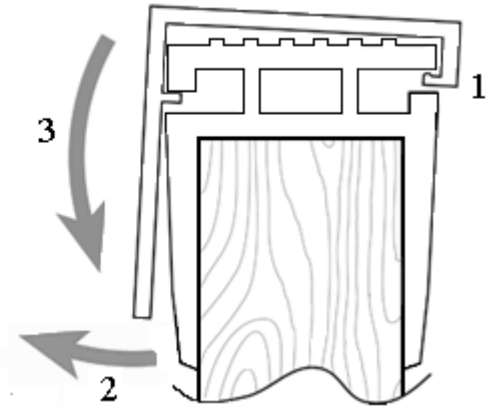

Figure 24-2



#### STEP #25

Assemble filter and ladder as per their individual instruction manuals.

#### STEP #26

Be **Extremely** careful and cut out the liner ( *with a razor* ) from the center ( *Inside* ) of the Skimmer and Return Face Plates. Use the Inside Edge of the Face Plate as a guide. Install water Directional Flow Fitting in the Return Fitting.

#### STEP #27

Safety placard **MUST** be installed where entrance or ladder to pool is located. No Diving Stickers **MUST** be placed on the liner. Space them evenly around the perimeter just below the coping.

#### STEP #28

After the pool is full of water, test the water for proper water balance. Proper sanitation levels ( *Chlorine or Bromine* ) should be maintained at all times. Improper ph will shorten the life of your liner and cause irritation to the skin and eyes! Follow all instruction for chemicals exactly. **DO NOT** place Chlorine or Bromine directly on liner, as bleaching will occur.

CAUTION - REMEMBER, ***NOT NOT*** JUMP or DIVE !!!!!!!!!!!  
THIS POOL IS FOR SWIMMING ONLY!

SERIOUS SPINAL OR OTHER INJURY CAN RESULT FROM DIVING,  
JUMPING, SLIDING, WALKING / SITTING ON TOP OF POOL WALL THIS POOL HAS  
BEEN DESIGNED FOR SWIMMING ONLY!

PLEASE REMEMBER TO FILL OUT, SIGN AND RETURN ALL  
WARRANTY/REGISTRATION CARDS.

# Drawing # 1

<b>DIG AREA CHART</b>			
Drawing # 1      6-3-99			
Dimension	POOL SIZE		
	12' x 24'	15' x 30'	18' x 33'
<b>A</b>	12'- 0"	15'- 0"	15'- 0"
<b>B</b>	11'- 7"	13'-1"	14'- 7"
<b>C</b>	10'-5"	11'-11"	13'- 5"

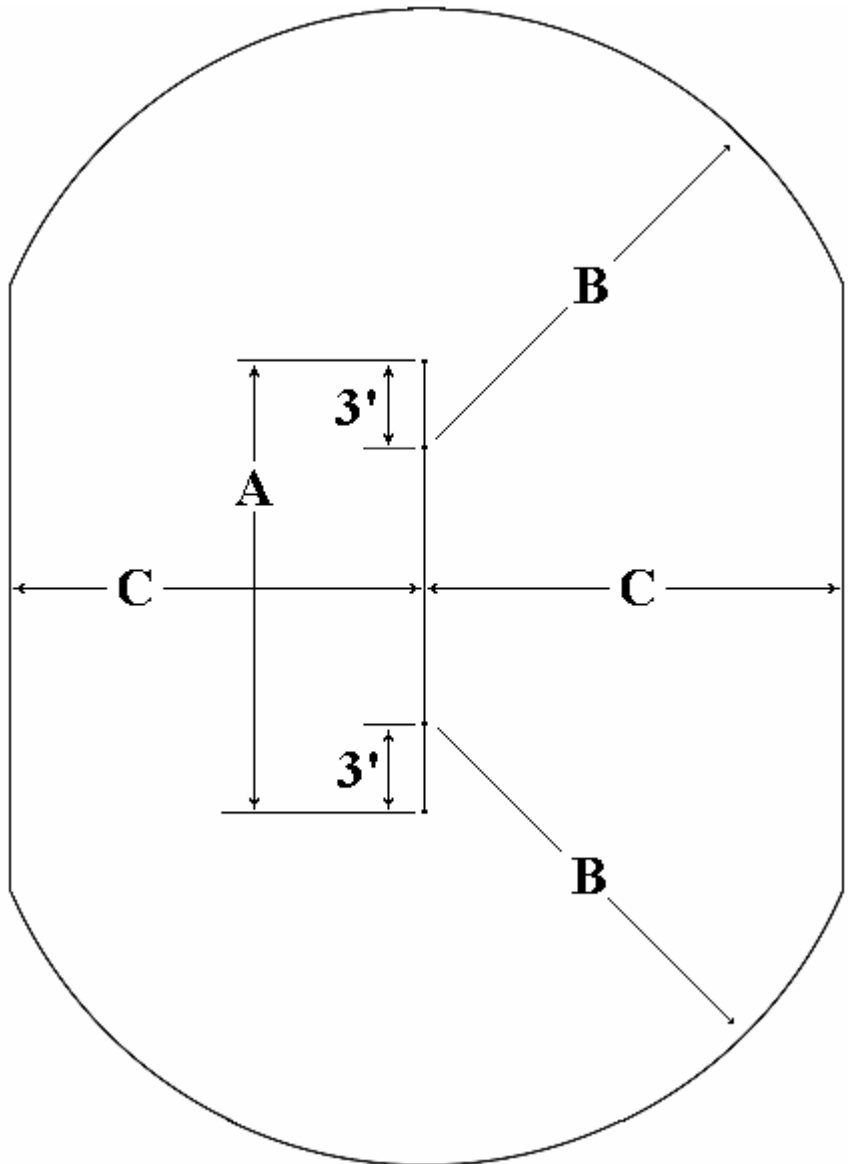

# Drawing # 2

## Concrete Pad Layout and Bottom Wall Support Location For Crestwood Oval Pools

Drawing # 2

6-3-99

### Concrete Requirements

**3500 # Mix Minimum**  
( Use #1 or Pea Stone if Available )

POOL SIZE	Concrete ( Cubic Yards )
12' x 24'	4
15' x 30'	4.5
18' x 33'	5

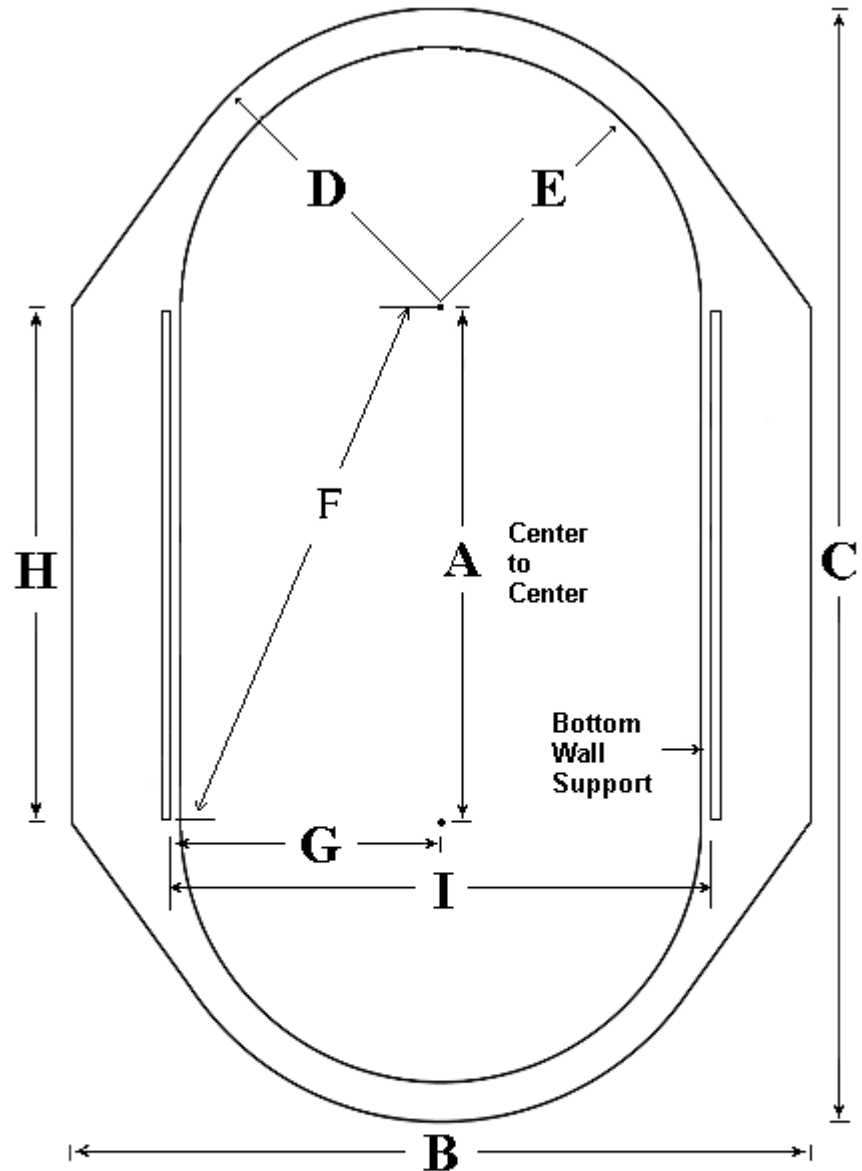

**IMPORTANT:** The dimensions listed are calculated using a tape measure hooked over a 3/8" metal stake. These dimensions are very critical; therefore be as accurate as possible when making any measurements.

Dimension	DIMENSIONS		
	POOL SIZE		
	12'x 24'	15'x 30'	18'x 33'
A	12'-0"	15'-0"	15'-0"
B	17'-10"	20'-10"	23'-10"
C	26'-2"	32'-2"	35'-2"
D	7'-1"	8'-7"	10'-1"
E	5'-11"	7'-5"	8'-11"
F	13'-5 15/16"	16'-10 1/4"	17'-6 15/16"
G	6'-1 11/16"	7'-7 11/16"	9'-1 11/16"
H	12'-6"	15'-6"	15'-6"
I	12'-3"	15'-3"	18'-3"

# Drawing # 3

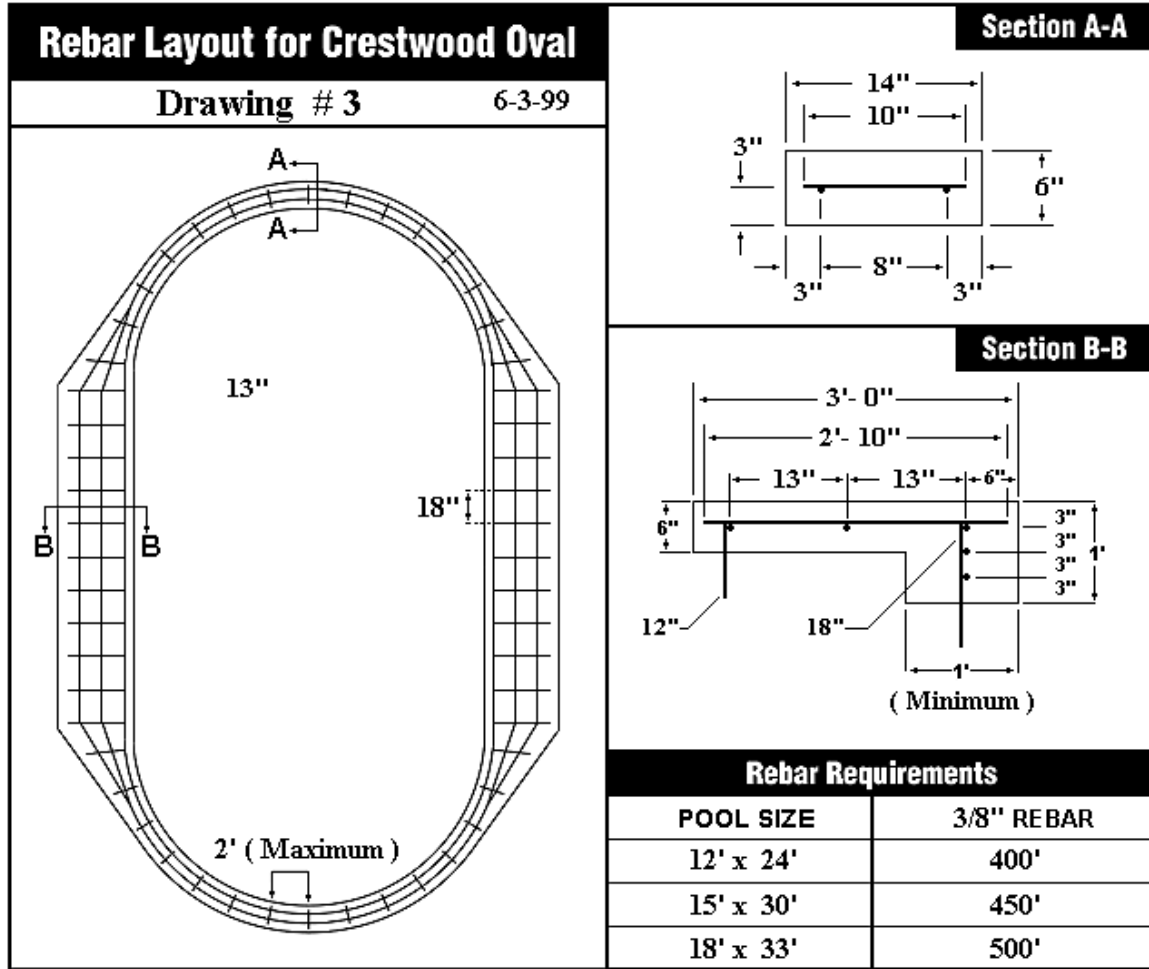

# Drawing # 4

## Brace and Support Details for Crestwood Ovals

Drawing # 4

Side View

6-3-99

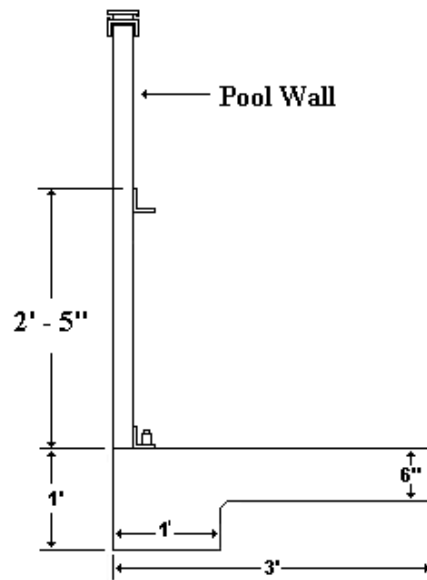
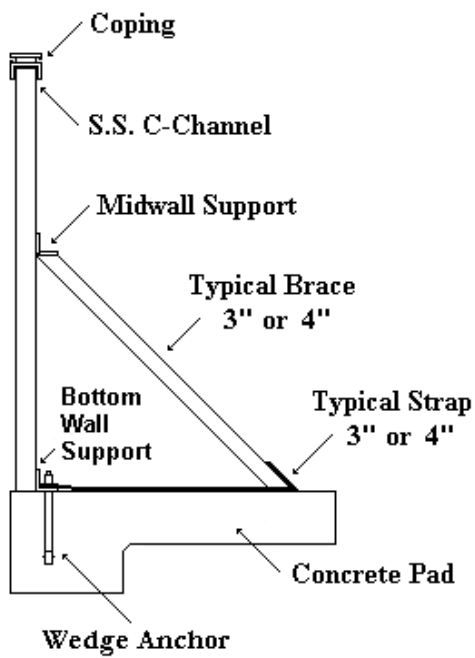

# Drawing # 5

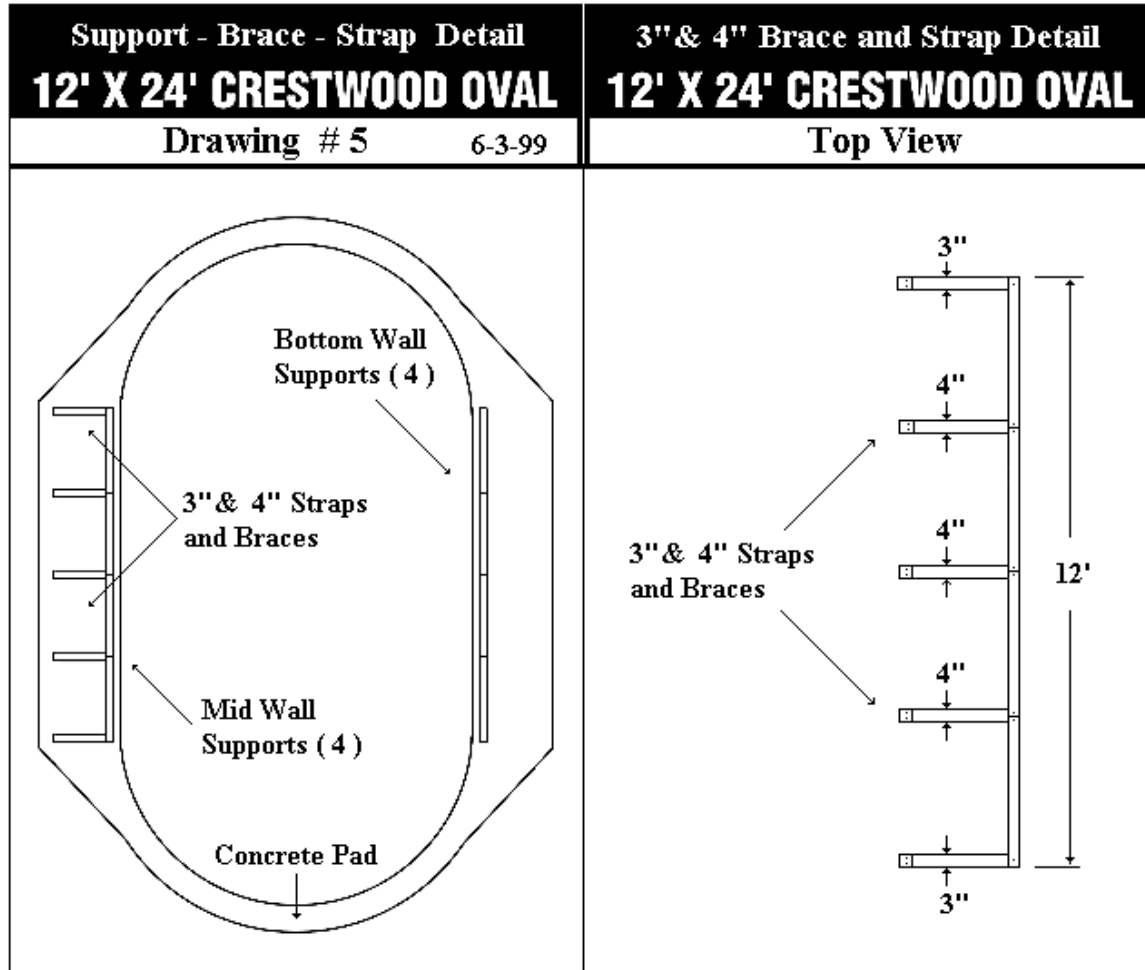

# Drawing # 6

