

CRESTWOOD POOLS

The *Ultimate* On-Ground Pool

Thank you for purchasing a CRESTWOOD POOL. We have incorporated over 100 years of combined pool experience with the finest materials and workmanship to provide your family with years of enjoyment and trouble free service.

Round Installation Manual

The wood used in your Crestwood Pool has been preserved by pressure treatment with an EPA - Registered Pesticide containing Copper Azol (CA) in order to protect it from insect attack and decay. CA penetrates deeply and remains in the pressure-treated wood for an extended period of time. Exposure to CA may present certain hazards. Therefore, the following precautions should be taken, both when handling the treated wood and in determining how to use or dispose of the treated wood:

- **Dispose of treated wood by ordinary trash collection or burial. Treated wood must not be burned in open fires or in stoves, fireplaces or residential boilers because toxic chemicals may be produced as part of the smoke and ashes.**
- **After working with the treated wood, and before drinking, eating or use of tobacco products, wash exposed areas thoroughly.**

CARE & MAINTENANCE

Even though your Crestwood Lumber has been pressure-treated with CA to inhibit fungus and bacteria that attack wood and cause decay, it is not waterproof. Water is still absorbed into and evaporated from the wood, which in time can cause discoloration, splits or checks. There is a full line of water repellent coatings and stains available through your Crestwood Pools, Inc. authorized dealer. These products are highly recommended to preserve the natural beauty of your Crestwood Pool and will help keep your investment looking like new.

Please Note: The wood has been Kiln Dried After Treatment and can be coated prior to or upon completion of the wall installation. No waiting time is necessary.

~~NOTE TO INSTALLER~~

It is extremely important that the following items be discussed with the Homeowner. After reviewing these precautions with the Homeowner, you **MUST** leave this Manual, Warranty Cards, and all Warnings with the Homeowner. It is also **REQUIRED** that all Warning Labels be applied to the liner and that the Safety Placard is installed at the entry point to the pool.

WARNING!! This swimming pool is **NOT** designed for Diving, Jumping, Sliding, Walking / Sitting on Top of Pool Wall. Serious or Fatal Injury can result from performing any of the above. Warning signs provided with pool kit **MUST** be displayed prominently and permanently throughout each swimming season. It is the Homeowners responsibility to do the following:

- Do **NOT** locate pool near objects that would entice diving (i.e. garages, trees, porches, etc.)
- Do **NOT** allow anyone to use your pool unless they are fully aware of the warnings listed above.

THIS POOL HAS BEEN DESIGNED FOR SWIMMING ONLY!

Do **NOT** place CHLORINE or BROMINE directly on LINER as BLEACHING will occur.

The liner manufacturer, Pocono Pool Products, recommends that all Homeowners initially and annually have the areas where the pool and filtration system will be installed inspected and/or treated for termites, ants and other insects. Some customers have experienced damage to their PVC Plumbing and Vinyl Liners due to insect infestation. Insect damage to the Liner or Plumbing/Filtration system is not covered under any of the warranties accompanying your pool therefore we strongly recommend that all customers take these precautionary measures.

Additionally, there is a rising occurrence of micro-bacteriological staining of liners. These micro-organisms are present in the soil and ingest the vinyl as a food source. The resulting secretions can cause discoloration, staining and/or the removal of the printed surface. To date no treatment exists to eliminate or diminish this problem. The vinyl calendaring companies and the pool industry as a whole are aware of these problems and are working for a solution. Should any treatment or preventative become available we will incorporate it into our product line immediately.

IMPORTANT: In Cold Climates there is a possibility of Frost Damage when Decking is built around only a portion of the pool and/or or if there is improper drainage. A differential in ground movement can occur due to snow acting as an insulator around the exposed portion of the pool while having no/or less snow under the decking and/or water in the ground due to improper drainage. Making sure there is proper drainage and placing snow under the decking should avoid the potential of Frost Damage. Insulating around the entire pool prior to the ground freezing is another alternative.

IMPORTANT: It is recommended to monitor the water level for a possible leak for 1 week prior to closing the pool for the winter. Closing the pool with a leak can cause liner/structural damage. It is possible to patch the liner under water, draining the water is **NOT** required.

Thank you for your understanding on the issues/info presented above. We will continue to make every effort to provide you with the most durable, long lasting pool package available.

In order for your warranties to be in effect please sign all acknowledgement / warranty cards provided and return them to the address listed on each card.

~~IMPORTANT~~

**BE SURE TO READ AND UNDERSTAND THE ENTIRE MANUAL
PRIOR TO BEGINNING YOUR CRESTWOOD POOL INSTALLATION**

HOMEOWNERS RESPONSIBILITY CHECKLIST

IMPORTANT: IT IS REQUIRED BY LAW TO CALL THE LOCAL *UNDERGROUND UTILITIES* LOCATING SERVICE PRIOR TO ANY EXCAVATING. THEY WILL LOCATE AND MARK BURIED TV, PHONE AND ELECTRIC LINES. (Failure to do this is not only dangerous, you will have to pay for the repair of any damaged utility lines)

**UPON RECEIPT OF POOL, CHECK PACKING LIST FOR SPECIFIC COMPONENTS,
OBTAIN A BUILDING PERMIT IF REQUIRED AND CHECK THE FOLLOWING:**

- 1. LOCAL BUILDING AND ZONING REQUIREMENTS**
- 2. ELECTRICAL & BONDING REQUIREMENTS**
- 3. FENCING REQUIREMENTS**
- 4. BACKWASH (Waste) REQUIREMENTS**
- 5. HAVE PROPER TOOLS AVAILABLE. (See List Page 4)**
- 6. OBTAIN INSTALLATION MATERIALS NOT SUPPLIED WITH YOUR POOL PACKAGE (Sand, Concrete, Rebar, Duct Tape, Etc. See Chart Below & Page 4 and 7)**

APPROXIMATE MATERIALS REQUIRED

POOL SIZE	SAND	8" x 16" x 1 1/2" or 2" PATIO BLOCKS
12'	1.5 TONS	34
15'	2 TONS	40
18'	3 TONS	47
21'	4 TONS	55
24'	5 TONS	62
27'	6 TONS	70

Please Note:

- Sand Requirements are Estimates Only - actual amount will vary depending upon conditions.
ORDER ACCORDINGLY !**

We recommend "Fine - Washed Sand" free of any stones or sharp objects.

TOOLS REQUIRED

3 - 3/8" DIAM. METAL STAKES FOR LAYOUT

LEVEL (4' and Torpedo)

TRANSIT (Available at Local Tool Rental Stores)

HACK SAW or WOOD SAW

TAPE MEASURES (50' Flexible Steel)

ROUND END MASON TROWELS, 12" TO 14"

CORDLESS or ELECT. PHILLIPS SCREWDRIVER

ELECTRIC DRILL

3/4" WRENCH or RATCHET WRENCH (All Size Pools)

15/16" WRENCH or RATCHET WRENCH (21',24',27' Pools)

WHEEL BARROW (Optional)

CONCRETE FORMS or MASONITE & WOOD STAKES (If Pouring Concrete Collar)

CONCRETE TOOLS: STEEL TROWELS, EDGER, BROOM (Optional)

SPECIAL BRACING TOOL (Available From Dealer) or 3 - 2" x 4" x 8' BOARDS

NOTE: CUT THE FOLLOWING LENGTHS FROM EACH 2" x 4" x 8' BOARD FOR STEP #6 :

1 - 12" SUPPORT BLOCK

1 - 5' BRACE

1 - 2' STAKE

DUCT TAPE

SHOP VAC

RAZOR KNIFE

GARDEN RAKE

SHOVEL

PICK or MATTOCK

WISE GRIPS

3/16" DRILL BIT

SPRAY ADHESIVE

NAILS or SCREWS

AFTER DETERMINING THE BEST POSSIBLE LOCATION FOR YOUR POOL BASED ON PROPERTY LINES, SEPTIC TANK, OVERHEAD POWER LINES, GROUND SLOPE ETC..... YOU ARE READY TO BEGIN GROUND PREPARATION.

IMPORTANT: THE POOL CAN NOT BE BACKFILLED. THERE MUST BE PROPER DRAINAGE TO KEEP WATER AWAY FROM THE POOL.

THE WARRANTY/GUARANTEE IS VOID IF THE POOL IS BACKFILLED OR IMPROPER DRAINAGE EXISTS.

STEP #1

After selecting a relatively level area, drive a stake (*3/8" diameter steel, 1/2" Threaded Rod as described in Step #20a, page 17 or wood*) in the ground at the center point of your pool. Locate an area, which will not interfere with excavation, and place offset stakes to enable relocation of center stake after excavation is completed.

Please Note:

- Offset stakes are extra stakes used during excavation that allow you to remove the center stake, excavate the area, then measure from the offset stakes to reposition the center stake necessary for continuing.
- If a wooden stake is used drive a nail into the top of the stake so that the tape measure can be easily attached.
- If a 3/8" steel stake or 1/2" Threaded Rod is used add 1/2 the diameter (*3/16" for 3/8" stake and 1/4" for 1/2" Threaded Rod*) to the measurements listed in Chart 1 below and Chart 2, page 7.

From the center stake, use the "A" dimension (*Dig Radius*) from Chart 1 and mark out a circle with chalk, lime, flour, etc. (Refer to Drawing #1, page 6).

Chart 1

POOL SIZE	A Dig Radius	B Scribe Line	C Radius at Center Point on Inside Edge of Block	TRUE RADIUS
12'	7' – 6"	6' – 3/4"	5' – 8 3/4"	6'
15'	9'	7' – 6 3/4"	7' – 2 3/4"	7' – 6"
18'	10' – 6"	9' – 3/4"	8' – 8 3/4"	9'
21'	12'	10' – 6 3/4"	10' – 2 3/4"	10' – 6"
24'	13' – 6"	12' – 3/4"	11' – 8 3/4"	12'
27'	15'	13' – 6 3/4"	13' – 2 3/4"	13' – 6"

Drawing # 1

LAYOUT DIMENSIONS

Drawing # 1

6-3-99

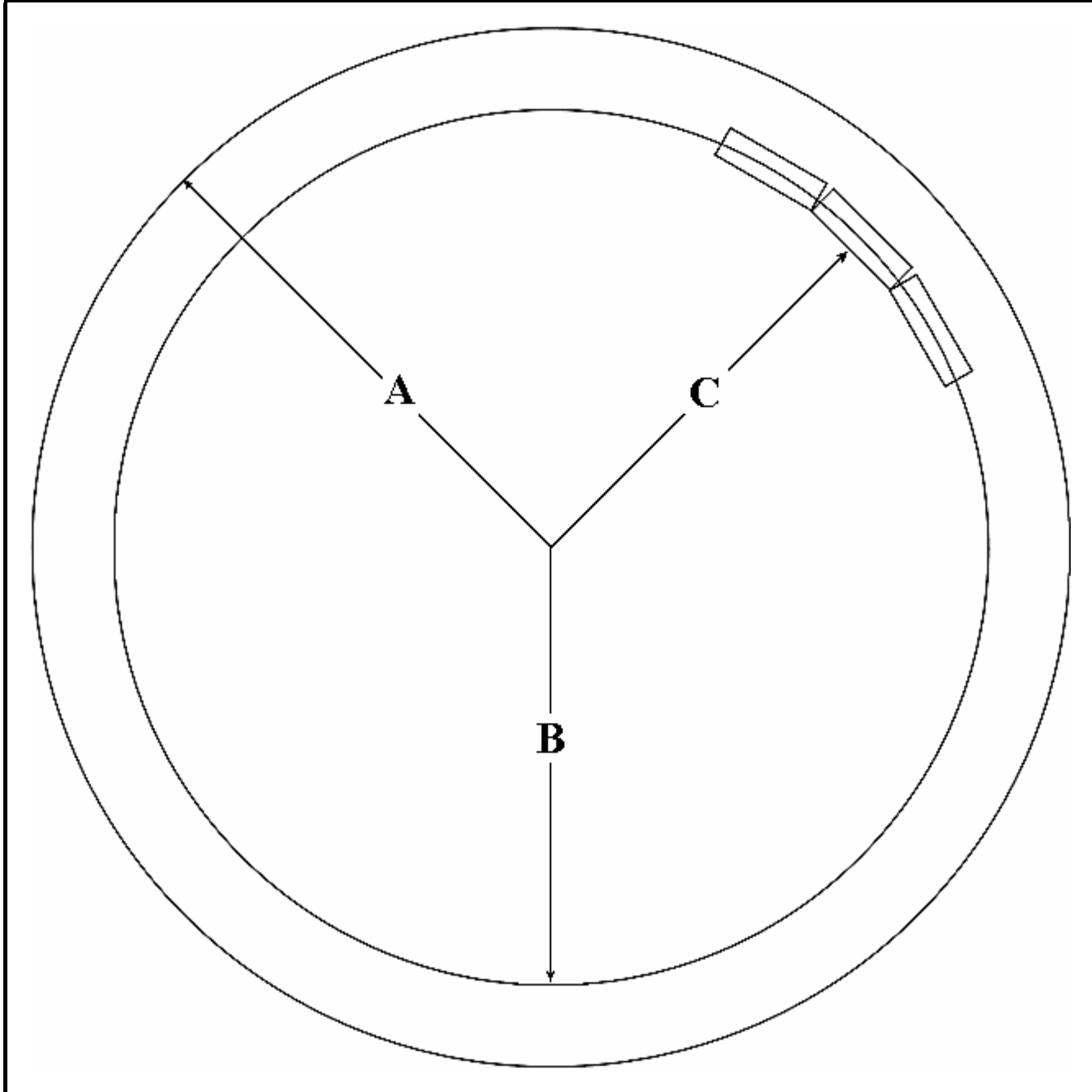

STEP #2

Remove the center stake and level the entire Dig Radius area. Remove all sod, roots, etc. from within the circle. Using a transit, locate the lowest spot in the circle and level the entire area to within 1/2" of the lowest spot .

IMPORTANT: It is necessary to set the pool on solid ground. **DO NOT** build up low areas when leveling the pool area. Instead dig down to the level of the lowest spot allowing the pool to rest on undisturbed earth. If the bottom of the pool is to be bowl shaped, the center can now be dug down to the desired depth 8" Maximum (Refer to Figure 2, page 7). Reset center stake.

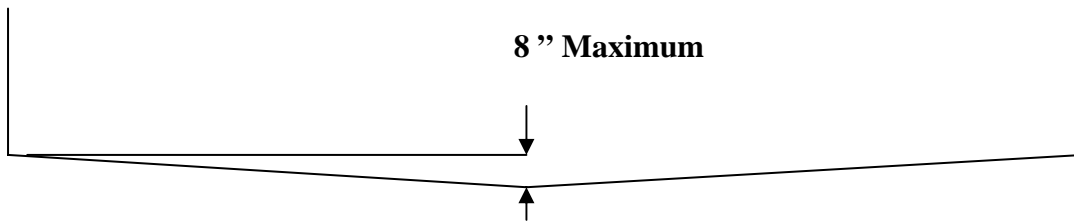

STEP #2a

If a concrete collar is to be poured instead of using blocks Refer to Drawing # 2. Forming for the concrete collar may be accomplished by using 3/8" x 4" or 6" x 8' Plywood or Flexible Metal Concrete Forms. Pound stakes in the ground so that the inside radius (I - R) and the outside radius (O - R) dimensions are measured to the Concrete side of the Plywood or Flexible Forms from the center stake (Refer to Chart 2).

Rebar & Form Layout for Crestwood Round Pools

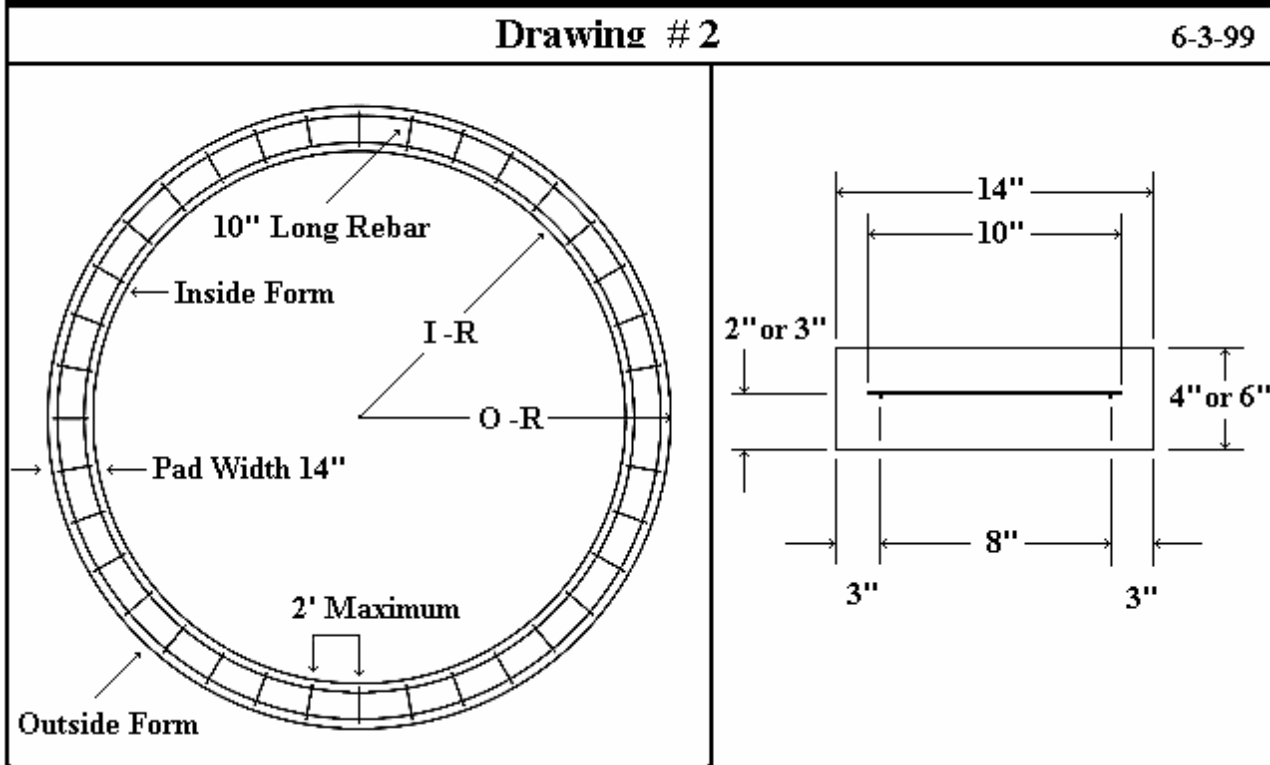

Chart 2

POOL SIZE	I - R	O - R	Concrete (Cubic Yds.)		3/8" Rebar Requirements
			4" Thick	6" Thick	
12'	5' - 11"	7' - 1"	.6 Yd.	.8 Yd.	150'
15'	7' - 5"	8' - 7"	.75 Yd.	1.1 Yds.	180'
18'	8' - 11"	10' - 1"	.9 Yd.	1.3 Yds.	210'
21'	10' - 5"	11' - 7"	1 Yd.	1.5 Yds.	240'
24'	11' - 11"	13' - 1"	1.15 Yds.	1.7 Yds.	270'
27'	13' - 5"	14' - 7"	1.3 Yds.	2 Yds.	300'

STEP #2a continued

Please Note:

- Concrete amounts listed in Chart 2 are exact quantities for depth of concrete shown. Varying depths of grade will necessitate adjustments to these quantities. Always order 1/2 to 3/4 yards more concrete than shown in Chart 2 (*plus extra amount required if a filtration pad will be poured*).
- 3500 # Concrete (Min.)

IMPORTANT: Be sure to follow local electrical codes prior to pouring footers to provide for electrical bonding or grounding for the filter and Cable Ends and Lugs. Usually a piece of rebar or grounding wire that is tied to the steel rebar reinforcement grid should be left extending out of the footer in 3 places (roughly 1/3 of the pool perimeter for each of the cables) and at the filter location. Consideration should be given to the placement of the filtration system. If it is desired, the concrete pad may be extended or a separate pad (3' x 4' min.) can be formed and poured to accommodate the filtration system (*most states require a minimum of 5' from waters edge*).

Completely level all forms using a transit or the alternative method described in Step 4 cont., page 9. When setting forms to grade, the Outside Forms should be 1/8" to the foot lower than the Inside forms to allow any water (*rain or splash over*) to run away from pool.

Example: If pouring a 14" wide Pad, the Outside form will be 1/8" - 3/16" lower than the Inside form. Once forms are leveled, place steel rebar as shown in Drawing # 2, page 7 making sure rebar is centered up and down within the forms. Concrete **MUST** be within 1/8" of level around entire perimeter. After concrete has cured for 1 day continue with STEP #5.

STEP #3

Using the method in STEP #1, mark out the "True Radius" dimension in Chart 1, page 5. Spread sand around the perimeter of the pool 6" to either side of the line - 1/2" to 1" thickness. The sand should be packed in place with a hand tamper or plate tamper. An alternative to setting the blocks on sand would be to set the blocks in a mortar mix similar to setting tile.

STEP #4

Start placing blocks (*in the sand*) measuring the " C " dimension in Chart 1, page 5 from the center stake to the center point on the Inside edge of the blocks. The Inside corners of the blocks should be touching (Refer to Figure 4-1). As the blocks are put into place, they **MUST** be leveled left to right and inside to outside, use the transit to make sure all blocks are at the same grade. ****Blocks should NOT be placed on more than 1/2" layer of sand.**

Please Note: After the pool installation is completed, it is important to protect the sand or material that the blocks were placed on from potential washouts caused by over-splash or rain. This is accomplished by covering the exposed area around the pool with some type of stone. (*Placing some type of landscaping fabric down first will keep weeds and grass from growing up through the stone*)

Figure 4-1

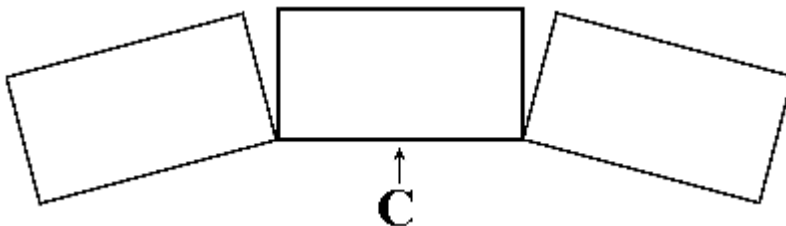

STEP #4 continued

An alternative method to using a transit for leveling blocks or concrete forms is to use a 3' length of Threaded Rod, a 2"x 4" board and a level (Refer to Figure 4-2). Go to STEP #20a, page 17 + 18 and read the instructions for building the Sand Leveling Gage. Following the instructions prepare and pound the Threaded Rod into the center of the pool making sure it is 4" higher than the ground level plus the thickness of the blocks (or concrete forms) where the blocks (or forms) will be placed. Set one block using the " C " dimension in Chart 1, page 5 and level or follow the instructions for STEP #2a, page 7 for pouring concrete. When measuring " C " or I - R + O - R dimension from the Outside of the Threaded Rod make sure to add 1/4". Select a 2"x 4" that is 6" longer (15" for concrete) than the True Radius listed in Chart 1, page 5 for your size pool. If one 2"x 4" is not long enough, screw two 2"x 4"s together as shown in Figure 4-2. Drill a 1/2" hole in the 2"x 4" about 1-1/2" from one end. Loosen the Nuts and thread them down the Threaded Rod. Slide the washer over the Threaded Rod. Slide the drilled end of the 2"x 4" over the Threaded Rod and place the other end on the leveled block or Inside concrete form. Place the level on the board and check for levelness. Adjust the Nuts until level and tighten them against each other. Place the 2"x 4" in the center of the block and make a mark on the board where the Inside edge of the block is (*this will represent the " C " dimension*). For concrete, place the 2"x 4" on the Inside form and make a mark on the board where the Concrete side of the form is (*this will represent the " I - R " dimension*). Continue placing the blocks or forms around the pool using the board to set and level them. After setting all Inside forms, measure Outward 14" from the Inside form and make a mark on the 2"x 4" (*this will represent the " O - R " dimension*). Tape a 1/8"-3/16" spacer on the bottom of the 2"x 4" where the mark is (*this will provide the proper slope away from the pool*). Set the Outside forms using the new mark.

Figure 4-2

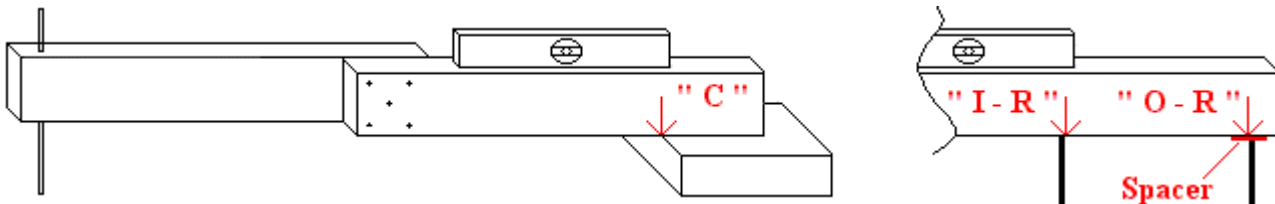

STEP #5

After all blocks have been properly placed and leveled, scribe a circle on the blocks (or concrete) using the " B " dimension (*Scribe Line*) in Chart 1, page 5. When measuring " B " dimension from the center of the stake or nail, be sure to add 1/2 of the diameter of the stake or nail your tape is hooked to at the center of the pool.

STEP #6

The remaining sand may now be placed in the center of the pool area by either shoveling it in or by removing a few of the blocks, backing a truck in and dumping the sand. After emptying and removing the truck, be sure to place the blocks back in their original position and re-level them. If a backhoe or loader is available it is recommended to put sand in after the pool wall is complete and wall foam is in place. **IMPORTANT:** The sand Must be tamped where it meets the Concrete Footing to avoid /minimize settling of the sand. It is best to spread the sand in 2"- 3" lifts and tamp each lift with a Plate Tamper until reaching the Top of the concrete. It is best to tamp the entire pool bottom. Tamping the sand prior to erecting the walls will allow easy access for getting the Tamper in and out of the pool.

STEP #7

IMPORTANT: There is a top and bottom to each individual board. It is Necessary that the first board be examined to insure proper placement. If properly placed, the Bottom Groove will measure 6" from the Bottom of the board. Boards must be placed so that the Grooved Side is facing Outward and the Smooth Side is facing Inward.

STEP #7 continued

To begin setting boards, start in the area where the filtration system will be located.

Please Note: The filtration system should be centered between the Skimmer and Return boards. Stand the two 2"x 6" Skimmer Boards, which are Shorter than the Standard Boards, (*Cable Grooves towards the Outside*) with the Inside Edge of the board on the Scribe Line (Refer to Figure 7-1). Check with the level to make sure the boards are standing perfectly straight and brace these two boards using the special tool available from your dealer (Refer to Figure 7-2).

If this tool is not available, nail or screw the 12" piece of 2"x 4" to the inside of the two boards. From this attach the 5' piece of 2"x 4" to a 2"x 4" stake driven into the ground while making sure boards are plumb (Refer to Figure 7-3).

Figure 7-1

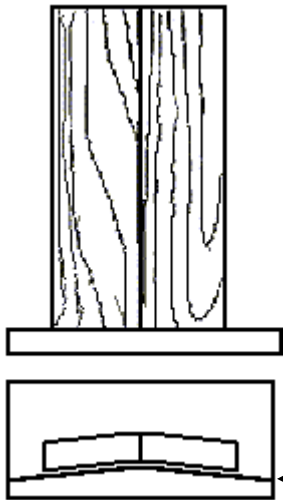

Figure 7-2

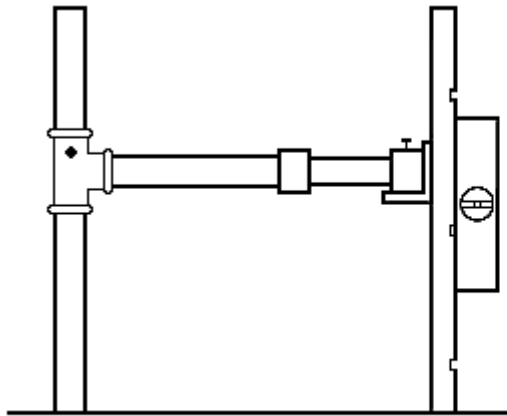
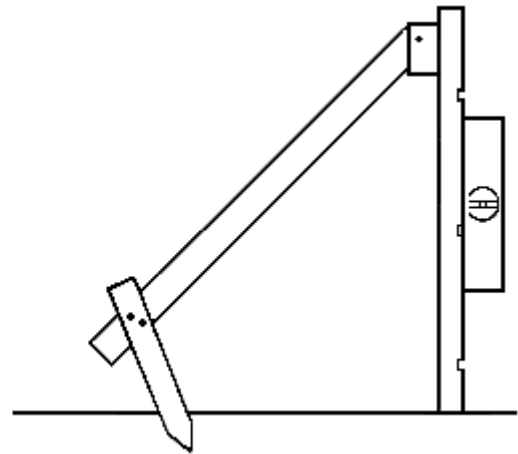

Figure 7-3



STEP #8

Place a 2"x 8" Standard Board on each side of the Skimmer Boards. To keep individual boards from disengaging while setting up the wall, center a section of Coping over the boards (Refer to Figure 8-1). Continue placing 2"x 8" Standard Boards for approximately 4' - 5' then install the Pre-Drilled Return Board (Refer to Figure 8-2). **Please Note:** If a Light will be installed, it should be placed within the filter area for easy electrical hook up. Install the Pre-Drilled Return /Light Board at this time. When placing boards keep boards as tight together as possible and make sure the Inside Edges are contacting each other from top to bottom with **NO** large gaps (*1/8" or larger is unacceptable*). Try switching a board to another location if the gap is too large.

Figure 8-1

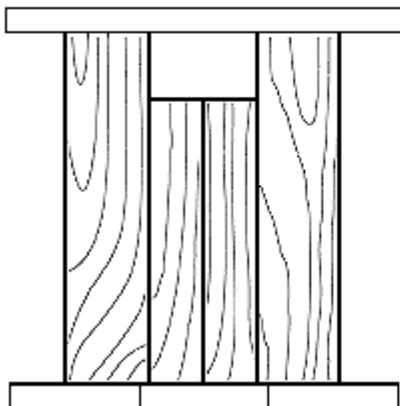
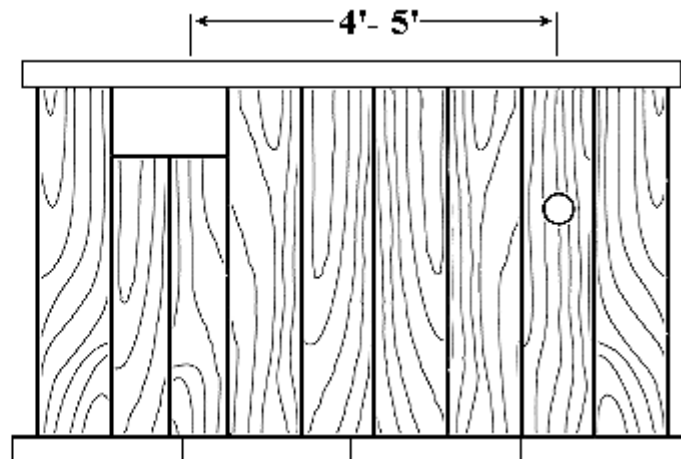

Figure 8-2



STEP #9

Continue adding 2"x 8" Standard Boards, making sure the Inside Edge of each board is on the Scribe Line. Add sections of Coping as necessary leaving a 1/2" gap between sections

(Refer to Figure 9). Install a Coping Clip over each Coping joint. Refer to Step #26, page 22 for Coping Clip Installation instructions.

Figure 9

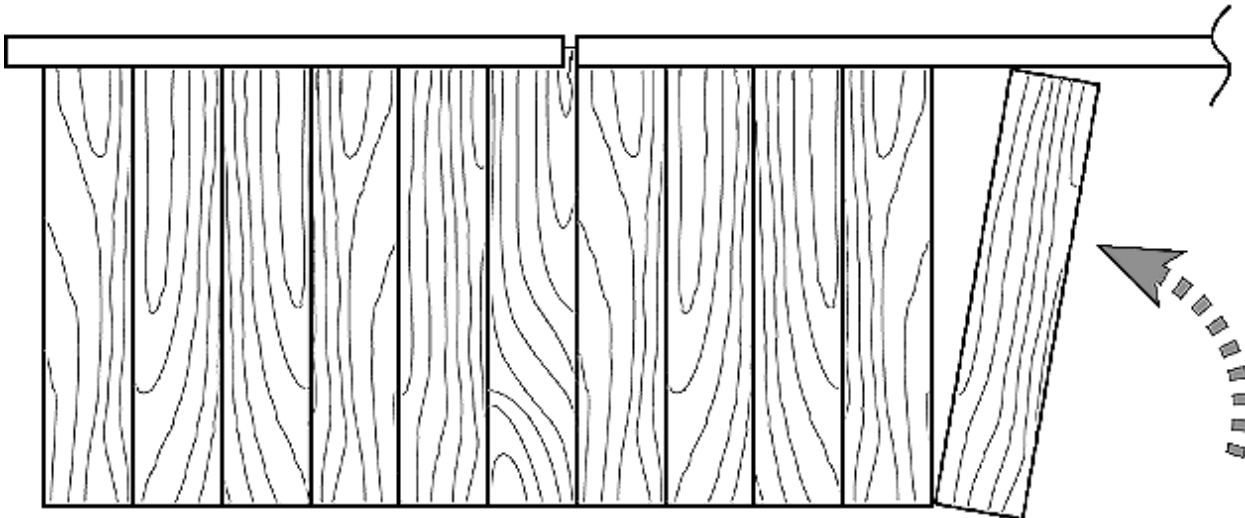

STEP #10

After placing every 10 to 20 boards check with the level to make sure boards are plumb (Refer to Figure 10-1). After placing every 20 to 30 boards, add another brace using the method described in STEP #7, page 10 or (*due to the tendency that the wall leans out at the top while erecting the pool*) wedge a board between the ground and the top cable groove (Refer to Figure 10-2). This is easily accomplished by the following procedure (1) have one person check and hold the wall plumb (2) lean a board against the pool wall so the top rests about 1/4" above the top cable groove (3) push Inward on the top of the wall only enough so the board slides down and drops into the cable groove. Recheck with level and adjust if necessary.

Figure 10-1

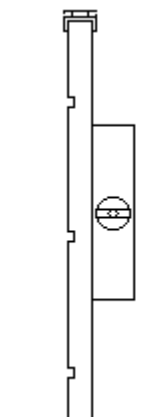
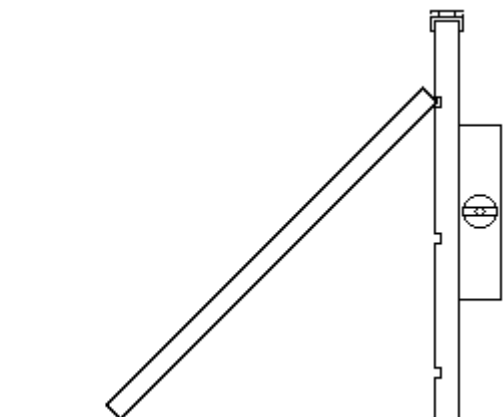

Figure 10-2



STEP #11

Continue adding boards using the above procedure (Steps #9 & #10) until you return to the starting point. There is 1 – 2”x 4” and 1 – 2”x 6” Filler Board supplied which may be used in combination with the Standard Boards to fill the final space. Extra boards are included in the pool kit to compensate for shipping damage or unusable boards. It is necessary to install only the number of boards required to complete the circle at the dimension listed on page 5.

STEP #12

After the entire pool wall is erected, **DO NOT** cut the last piece of coping to the proper length, leave it long. Measure the diameter of the pool at 3 or 4 places, making sure that the pool diameter is 1” to 1-1/2” larger than the desired pool diameter (Refer to Chart 1, Pool Size, page 5). Be sure to measure the pool diameter from the Inside Edge of the coping. After installing and tightening the cables, the boards will mesh together more tightly and the measurement will be slightly larger than the desired finished diameter. (*This is normal*)

STEP #13

Before installing and while tightening the cables, make sure there is still a 1/2” gap between the coping sections at each joint. As the cables are installed and tightened the gaps will close and it may be necessary to slide the coping sections apart or trim one piece of coping to maintain the proper gaps. Maintaining the proper gaps will allow the boards to engage tightly. Install the cables starting with the middle, then bottom, then top.

Please Note:

- There are two different size cable assemblies provided for 21', 24' and 27' pools. The Larger diameter cable MUST be installed in the Bottom cable groove. The smaller diameter cable will be used for the Middle and Top cable grooves.
- A small bead of the NEVER-SEEZ compound provided in the kit MUST be applied to all threaded ends on cables.
- Lugs MUST NOT be installed directly over each other. Stagger lugs approximately one-third of pool perimeter.

After the walls are totally erected, install the Middle cable. To install a cable, place one threaded end through the lug making sure the stud is directed away from the pool wall. Slide the lug over the cable exposing all threads. Apply NEVER-SEEZ to threads. Install the washer and nut. Slide the lug back over the thread (Refer to Figure 13-1).

Figure 13-1

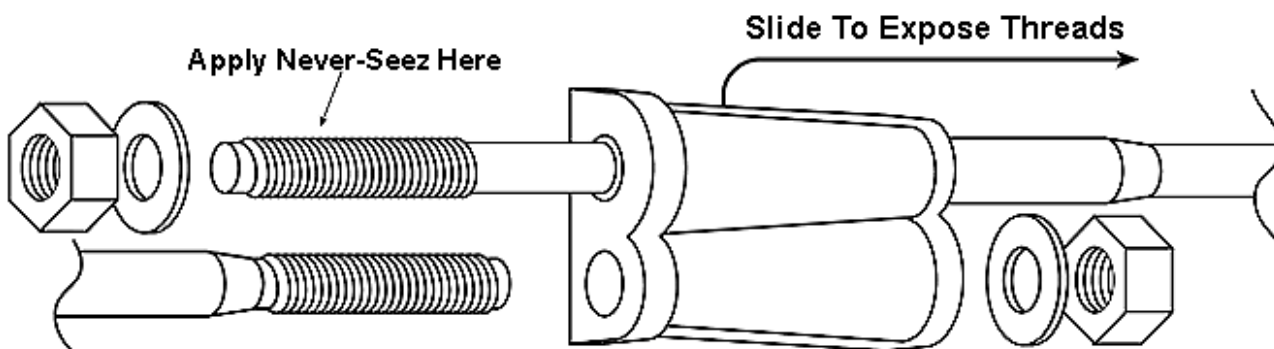

STEP #13 continued

It is easier to install cables with two people. One person should hold the lug aligned in the groove, while the second person unwinds the cable and inserts it into the groove keeping constant tension on the cable. When the Starting point is reached, make sure the loose threaded end of the cable protrudes past the lug approximately 1" so that the washer and nut can be installed. If the washer and nut can be started, apply NEVER-SEEZ to threads, insert through lug, install washer and nut. If the washer and nut **Can Not** be installed, the Cable-Tensioning Tool (*available from your dealer*) will need to be used as shown in Figure 13-2. Install the Cable-Tensioning Tool by inserting stud through lug as shown in Figure 13-2. Place the nut on the stud. Insert cable end through tube and thread nut on as far as possible. Apply pressure in direction shown. While tension is being applied, another person should walk around pool lightly kicking the **Bottom** of pool wall inward while shaking the **Top**. This will engage the boards making it possible to install a washer and nut on threaded end. Make sure cable end is at least 1" past the end of the lug so that there is enough slack to start the nut and washer. Remove the Cable-Tensioning Tool while keeping the cable tight (*this is best accomplished by having a person push the cable into the cable groove on either side of the person(s) removing the Tensioning Tool*); apply Never-Seez, washer and nut as stated above. If the cable end still will **Not** protrude 1" past the lug a board must be taken out. To remove a board keep slight tension on Tensioning Tool, then remove a section of coping (**NOT** in the area where Tensioning Tool is being used). Remove a board from the center where the coping was removed and install a smaller filler or combination of boards, which will equal the amount of cable needed to let the end protrude 1" past the lug. Replace coping section and repeat the above procedure for the Cable Tensioning Tool.

Figure 13-2

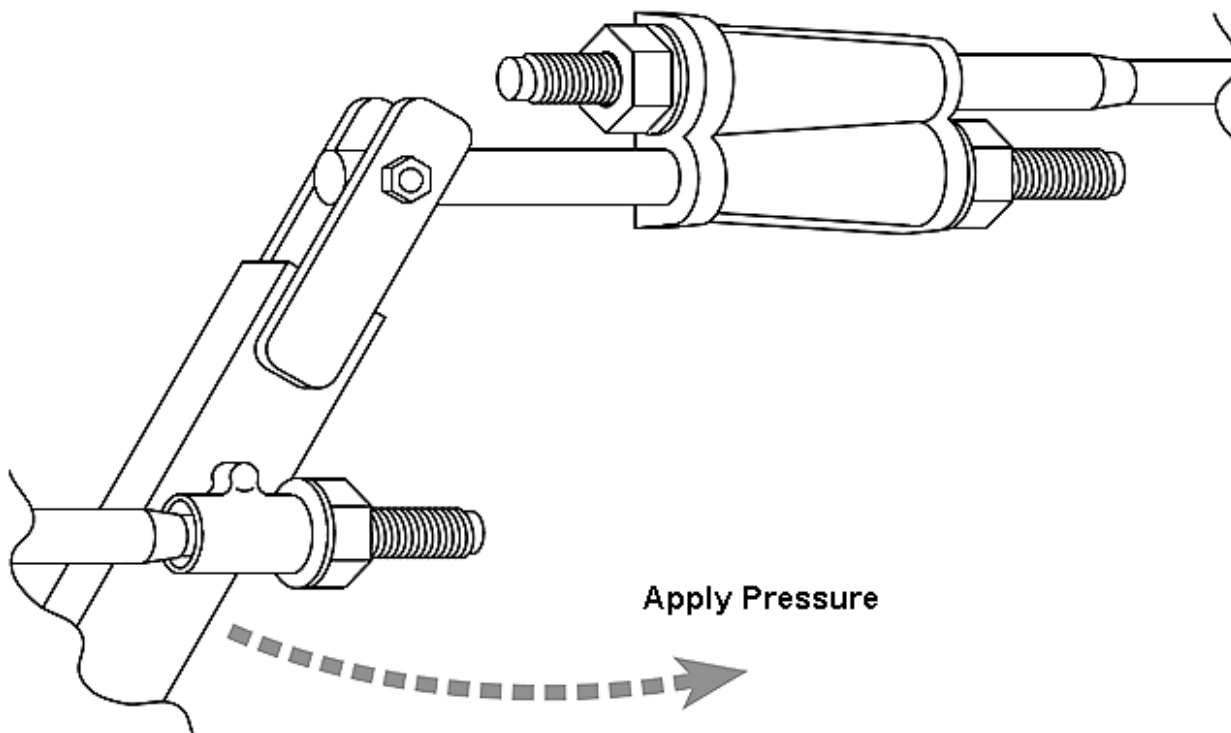

STEP #14

Tighten the Middle cable until all of the slack is out of the cable (*when tightening the nut, you will have to hold the opposite end of the stud with vise grips*). Remove the bracing tool or wooden bracing. Install the Bottom (*Large for 21', 24' and 27'*) and Top cables, tightening the three cables alternately, placing a level on the boards and adjusting the tension to plumb the boards (Refer to Figure 14) Tighten the cables as tight as reasonably possible. The pool wall will become very rigid when the cables are properly tightened. **IMPORTANT:** Make sure all cables are tight ! Insufficient tightening of the cables can cause a loose pool wall with excessive gaps between boards.

Figure 14

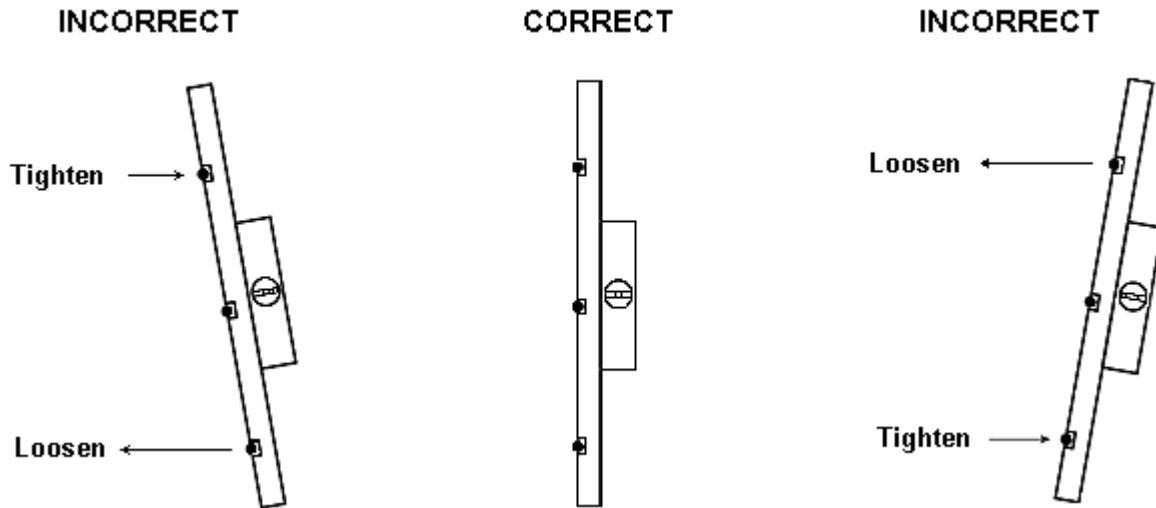

STEP #15

After tightening the cables, be sure that all coping joints are tight. It may be necessary to slide or trim the sections of coping so the joints Line Up with the board joints. Cut the overlapping piece of coping so that it fits into place. Install black protective caps over cable threads.

STEP #16

Remove the section of coping where the skimmer will be installed. Attach the Skimmer Mounting Brackets to the skimmer flange using (6) #10 x 3/4" S.S. Coping screws (3 on each side). The screws will pass through the holes in the skimmer flange and thread into the Pre-Punched holes in the bracket (Refer to Figure 16-1). Place the skimmer over the two short boards. Level the skimmer body before mounting it to the pool (*a non-level skimmer will be very noticeable when the pool is filled with water*). Attach the brackets to the wall using 6 Coping screws (3 on each side). The screws will pass through the Pre-Punched holes in the bracket and thread into the pool wall (Refer to Figure 16-2). The skimmer filler board **MUST** be installed while replacing the section of coping. Install filler so the cut side faces up and down (Refer to Figure 16-3).

Figure 16-1

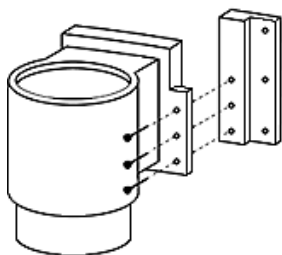

Figure 16-2

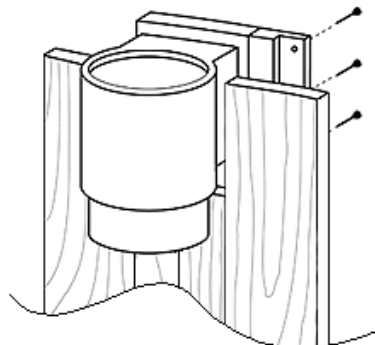
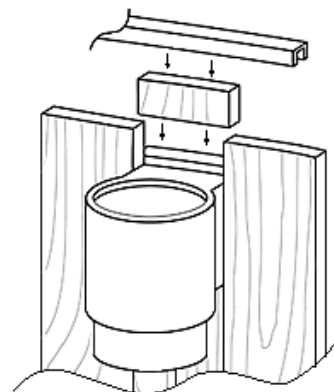

Figure 16-3



STEP #17

Standing Outside the pool, Pre-drill the coping (**DO NOT** drill wood) with a 3/16" drill bit. Drill the first hole approximately 2 1/2" away from a coping joint then drill additional holes approximately every 2'. **DO NOT** drill a hole within 2 1/2" of each coping joint or it will interfere with the coping clips (Refer to Figure 17-1). Hold a coping clip centered on the joint as a guide, then drill a hole about 3/8" to either side of the clip. Try to position each hole in the center of a board, not at the edge. Installing a coping screw into the edge of a board will result in a split edge. After all holes are pre-drilled, install a #10 x 3/4" S.S. Coping screw in each hole while holding the coping down against the top of the wood wall. **IMPORTANT:** Make sure coping is fully seated on the wood wall (Refer to Figure 17-2). Tighten screws so screw head just contacts coping. **DO NOT** Over-Tighten the screws or cracking may occur.

Figure 17-1

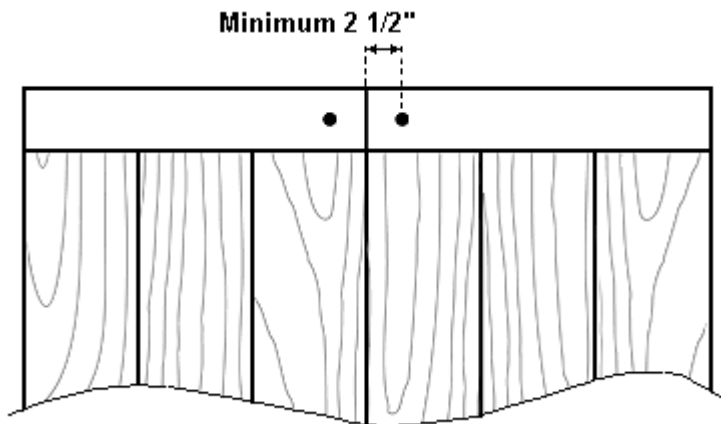
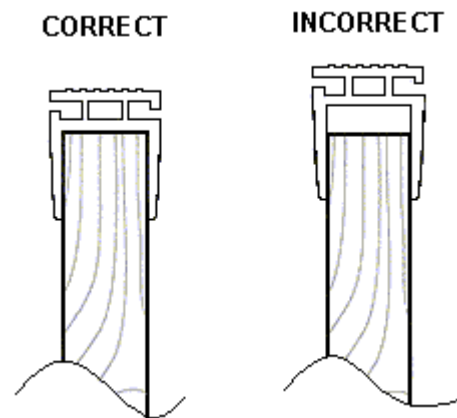

Figure 17-2



STEP #18

Cover any decayed knots (holes) or large imperfections on the inside wall surface with duct tape or wood filler before installing wall foam. Place the wall foam inside the pool wall and begin unrolling and taping it to the coping with duct tape (Refer to Figure 18-1 and 18-2). **Please Note:** If a vac will be used to remove wrinkles and insure a better liner fit as described in STEP #23, page 20, it is necessary to attach the foam to the bottom of the pool wall. Use spray adhesive or a 3/4" inch roofing nail placed in each board for 4 - 6 feet to either side of where the vac will be placed so the vac will not pull the foam up from behind the sand cove. A good place to do this is between the skimmer and return fittings so you have a guide to where the foam is attached to the wall. Continue around perimeter of pool overlapping foam at the starting point. Cut through both layers of foam to get a matched joint, then tape the joint (Refer to Figure 18-3). Spray adhesive is recommended around the entire perimeter of the pool to hold foam to wall.

Figure 18-1

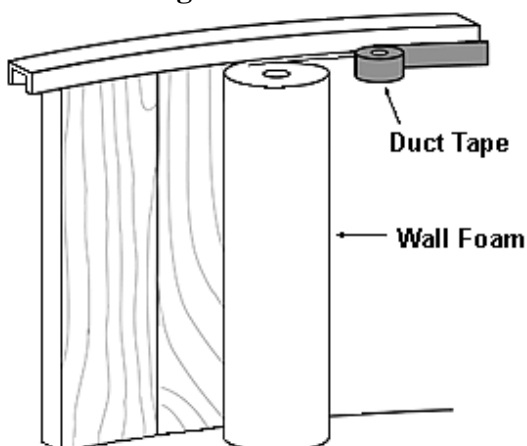

Figure 18-2

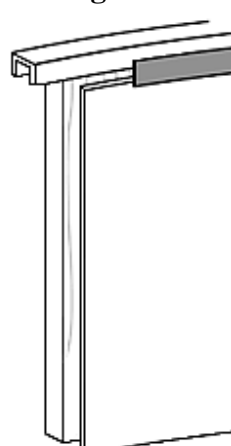
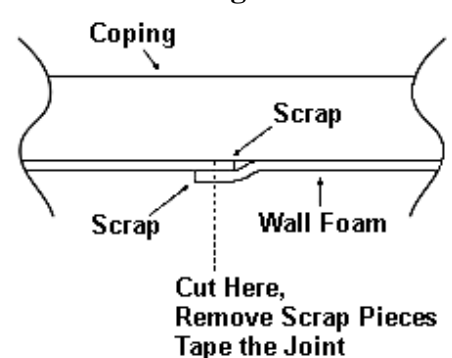

Figure 18-3



STEP #19

The foam **MUST** be removed from where the Skimmer, Return Fitting / Light Fitting (s) will be installed. Using the Outside Edge of the Skimmer as a guide cut and remove the foam covering the Skimmer (Refer to Figure 19-1). After removing the cut pieces of foam, tape the foam to the pool wall. Next install one (1) Skimmer Gasket directly to the face of the Skimmer using either tape or spray adhesive. Align all the holes in the Gasket with the Skimmer holes; be sure **NOT** to cover the holes with tape. Using the hole on the Inside of the pool as a guide cut and remove the foam covering the hole in the Return / Light Board (Refer to Figure 19-2). Please Note: If a Light is to be installed, proceed to STEP #25, page 21 and read the light installation information. Install a Return Fitting or Light Fitting by sliding the Fitting into the wall from the Inside of the pool. The foam will be sandwiched between the wood and the Fitting. Install the nut (*Flats toward wood*) as shown in Figure 19-3 and tighten. **HAND TIGHTEN ONLY.**

Figure 19-1

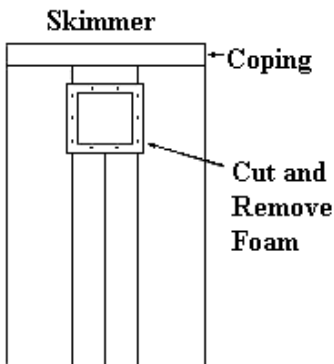

Figure 19-2

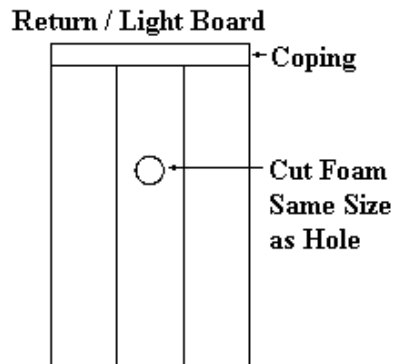
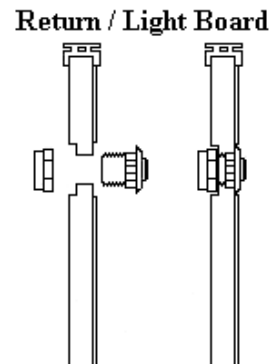

Figure 19-3



STEP #20

Spread sand evenly around pool bottom with a rake and trowel it smooth. Sand should be a minimum of 2" thick and may have a small cove at the base of wall. The sand can be dampened to make it easier to work with (Refer to Figure 20 - 1). **IMPORTANT:** Be sure to pack or tamp the sand at the cove area to reduce the chances of settling when the pool is filled with water.

Figure 20 - 1

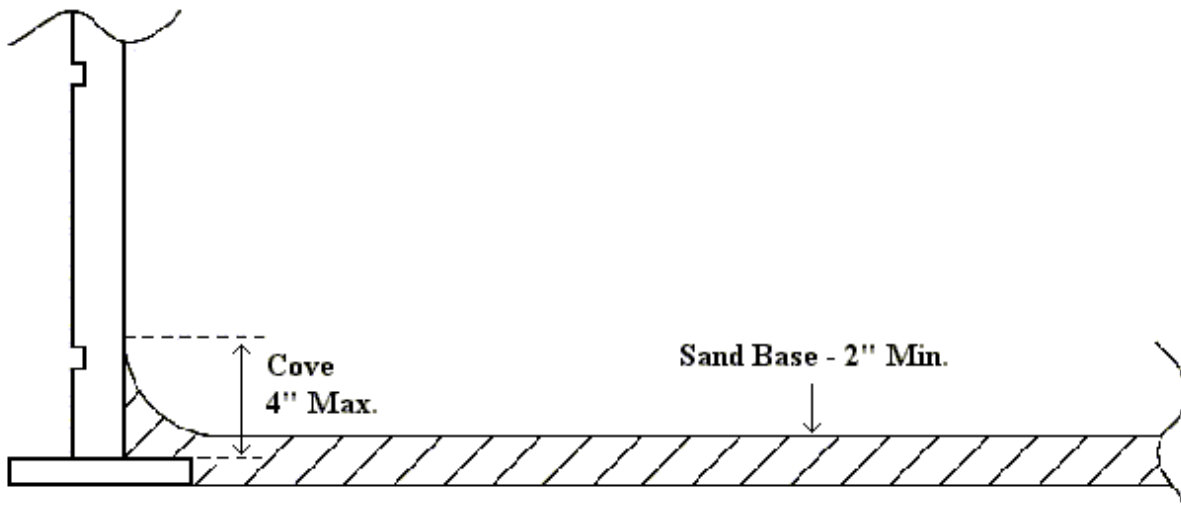

STEP #20a OPTIONAL INSTRUCTIONS

A Sand Leveling Gage can be easily built that will aid in finishing the sand bottom.

Materials Needed:

- 1- 2"x 4" 2" longer than the True Radius for your pool size listed in Chart 1, page 5
- 1- 8' long 2"x 4"
- 1- 3' long 1/2" Threaded Rod
- 2- 1/2" Nuts
- 1- 1/2" Flat Washer or 1/2" Fender Washer
- 10- 2-1/2" Deck Screws

Tools Needed:

- 1/2" Drill Bit
- 3/16" Drill Bit
- Drill
- 2- 3/4" Wrenches or tool suitable to tighten the 1/2" nuts together
- Screw Driver or suitable bit for drill to drive Deck Screws
- Hammer

Thread the Nuts on the Threaded Rod so that the top Nut is just above the end thread. Tighten the Nuts against each other (*this will protect the threads from damage when pounding it in the ground*). If another stake was used to layout and set the blocks or concrete, remove it and pound in the Threaded Rod until it becomes solid with no side to side movement (*it is critical that this is in the center of the pool*). Measure 2" up from the block or concrete and make a mark on the wall foam. Lay the long 2"x 4" next to the Threaded Rod extending to the pool wall. Leave a 1/4" gap between the end of the 2"x 4" and the pool wall. Mark the centerline of the Threaded Rod on the 2"X 4". Mark the centerline of the 2"x 4" and Drill a 1/2" hole through the 2"x 4" where the two marks intersect. Loosen the Nuts and thread them down the Threaded Rod to the desired finished height of the sand. Lock the Nuts in place by tightening them against each other. Slide the Washer down the Threaded Rod so it rests on the Nuts. Slide the 2"x 4" down the Threaded Rod so it rests on the Washer (Refer to Figure 20-2 *A*). Swing the 2"x 4" around the entire perimeter of the pool to verify that the pool wall is the same distance away from the Threaded Rod in the center. It might be necessary to move the wall in or out in spots to accomplish this. The 2"x 4" may need to be trimmed if it is hitting most of the way around the pool. Cut a 52" long piece from the 8' 2"x 4". Pre drill (5) 3/16" holes on one end as shown in Figure 20-2 * B *. While one-person holds the Bottom of the long 2"x 4" even with the mark on the wall foam, attach the 52" board to the long 2"x 4" using the 2-1/2" Deck Screws. There should be a 1/4" gap between the vertical board and the pool wall. Pre drill (3) 3/16" holes on the centerline of the remaining piece of 8' 2"x 4" as shown in Figure 20-3. Lay the piece on the coping and attach it to the vertical board using the 2-1/2" Deck Screws (Refer to Figure 20-3 * C *). Two people will be needed to operate the Sand Leveling Gage properly. One will hold the 2"x 4" on the washer in the center of the pool while the other person slides the Gage around the pool using one hand on the long 2"x 4" and one hand on the vertical 2"x 4". Place the sand inside the pool and spread around the entire pool. Tamp the area close to and over the edge of the blocks or concrete. Rotate the Gage around the perimeter while adding or raking away the sand until the sand is even with the bottom of the long 2"x 4" and the horizontal board lays flat on the coping. It may be necessary to slide the Gage over an area several times and rake away the sand that is building up along the edge of long 2"x 4". The entire pool may be tamped or rolled to provide a more solid base that will resist footprints, etc. For a smoother bottom you may want to trowel over the entire area after or while using the Sand Leveling Gage.

STEP #20a continued

After leveling the entire bottom the Sand Leveling Gage may be removed. Unscrew the 5 screws that are holding the vertical and long 2" x 4" boards together and remove. Lift the long 2" x 4" off the Threaded Rod and remove. Pull out the Threaded Rod (*it may be necessary to turn the Threaded Rod in a counter-clockwise direction using the bottom nut to unscrew it out of the ground*). Once the Threaded Rod is removed fill in the hole and trowel or smooth out that area and any foot prints as you work your way from the center of the pool to the wall. Jump out of the pool or place a ladder in the pool so you can get out. Lay on top of the wall and reach down to smooth out any remaining imperfections. If you are unable to do this you can tape a trowel to a board or use the end of a board to smooth out the area. Continue with STEP #21, page 19.

Figure 20-2

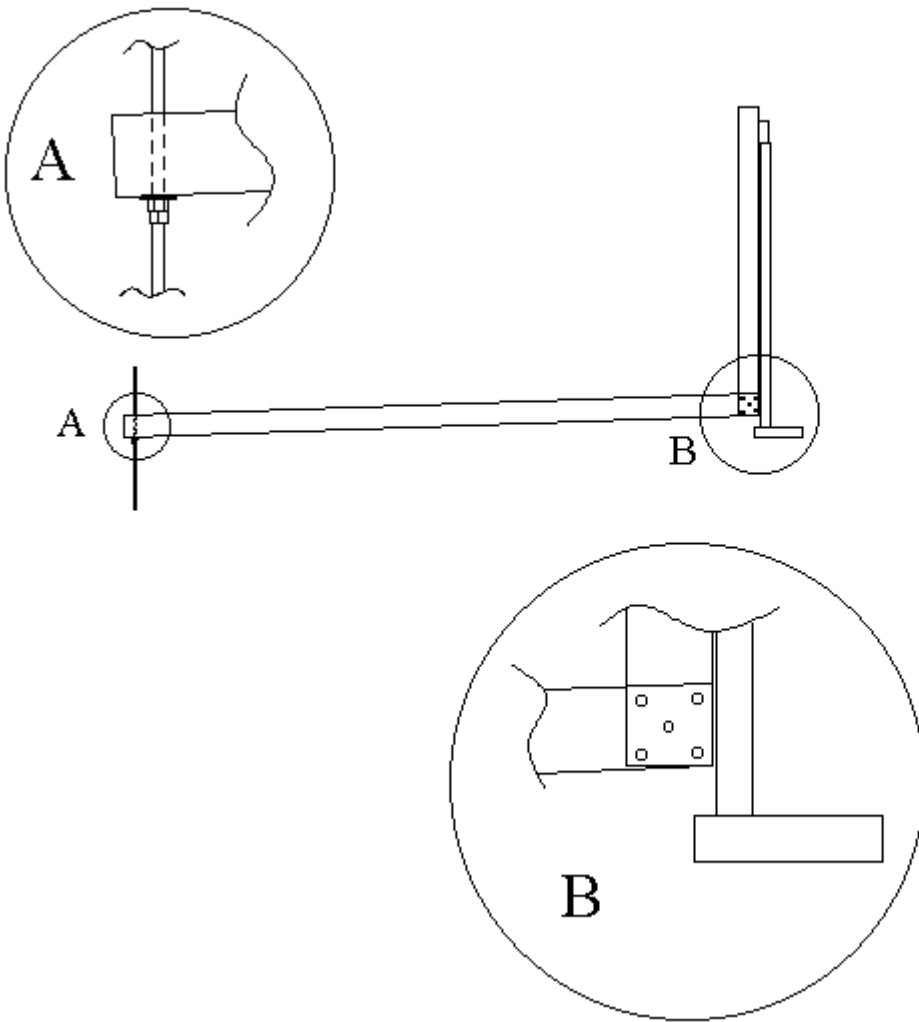
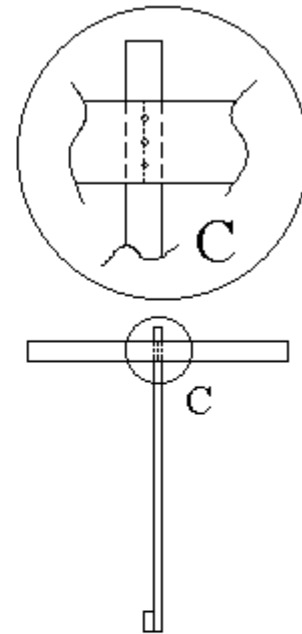

Figure 20-3



STEP #21

Prior to installing liner, it is beneficial to open liner up to allow the material to relax and remove some of the package wrinkles. Make sure area where the liner will be opened is free of any objects that could damage the liner. Take notice how the liner is fan folded so you can refold it in the same manner prior to installing it into pool. Remove the coping clips

(Refer to STEP #26,page 22) and tape over the joints. Be careful not to tape over the liner track on the Inside Edge of the coping. To install your liner, it is best to have 3 or 4 people present. Make sure there are no objects that could damage the liner on the ground where the liner is to be opened. Place the liner as close to the pool as possible (*position B*) and unroll toward position A & C (Refer to Figure 21-1). The liner is fan folded accordion style for ease of installation (Refer to Figure 21-2).

Figure 21-1

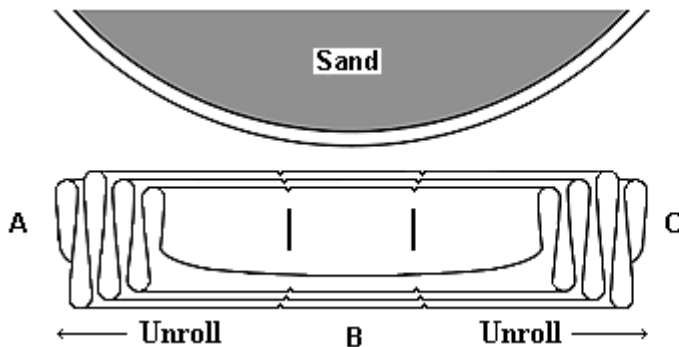
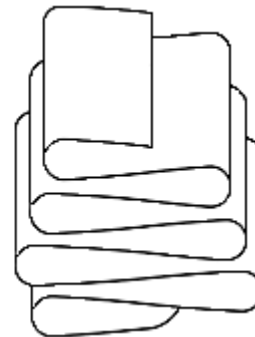

Figure 21-2



STEP #22

Make sure the liner is positioned so the heavy tab (*Bead Portion*) can be inserted into the inside groove of the coping (Refer to Figure 22-1). The people in positions A, B and C can now lift the entire liner up and over the pool wall. As the person in Position B starts inserting the bead into the inside groove, Persons A and C, can gradually walk around the pool allowing a small portion of the liner to unfold (*one fold at a time*) while taking special care not to drag the liner across the sand bottom. (Refer to Figure 22-2). Position B can continue inserting the bead around the perimeter of the pool until the liner bead is completely inserted into the groove. It may be necessary to go back to the starting position and slide the liner towards the area opposite the starting point. This will give you the amount of slack necessary to completely snap in liner.

Figure 22-1

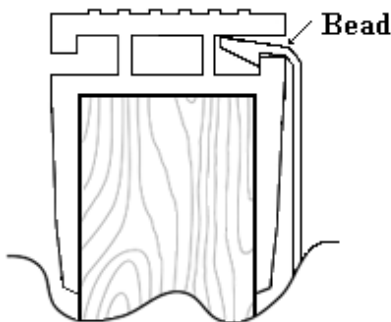
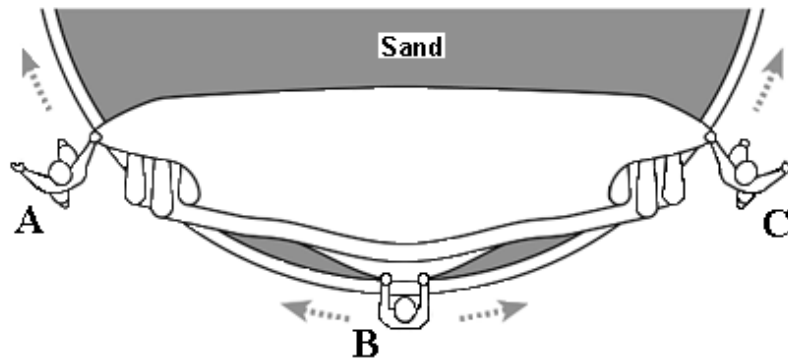

Figure 22-2



STEP #23

To remove most of the wrinkles, reach down to the bottom of the pool wall and push the liner back against the wall or push the liner Outward with a broom (**** Make sure there are *No sharp protrusions on the broom***). Be careful not to damage sand (*cove*) under liner. To remove any remaining wrinkles and to insure a perfect fit, a heavy-duty shop vac should be used. Take a small section, 8" – 12", of the liner out of the track and insert the vac hose 6" – 12" from the pool bottom. Tape around the vacuum hose, skimmer, return and light holes as well as all other possible air leak areas to ensure a good seal (Refer to Figure 23). Turn the vac on and the wrinkles should disappear.

Figure 23

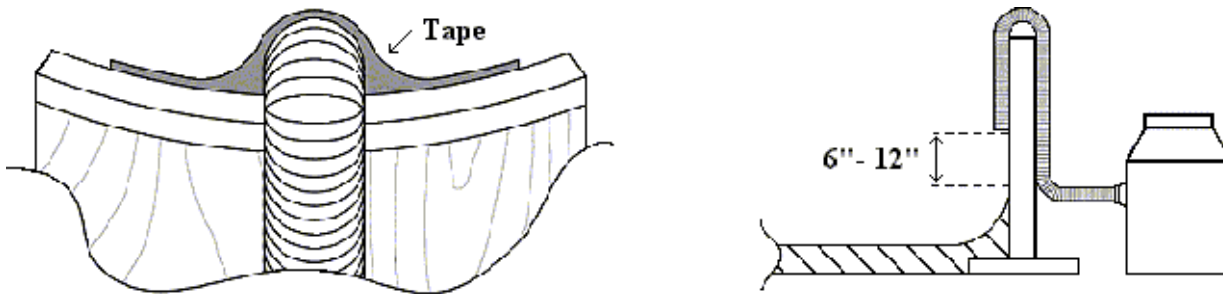

If all wrinkles are not removed by the vac, it may be necessary to work the wrinkles Outward (*toward wall*) while water is filling. This is accomplished by lightly tapping the liner outward with a broom at the base of the wall (****Make sure there are *No sharp protrusions on the broom***). Be careful not to damage sand (*cove*) under liner. It may be necessary to turn the vac off and reposition the liner to be able to work the wrinkles out. After the wrinkles have been worked out, continue filling the pool. If wrinkles still exist they may be worked out as the water is filling . **DO NOT** allow any wrinkles to be covered with water that will not be held out by the water pressure. Once the water is in; you will not be able to move the liner. Allow 3"- 4" of water to cover the entire bottom of the pool before turning off and removing the vacuum.

STEP #24

Fill the pool until it is approximately 2" Below the Return Fitting and Light Fitting if used. Attach the Return / Light Face Plate by carefully locating the screw holes through the liner and screwing the Face Plate on uniformly and snugly. Repeat this procedure on the Skimmer when the water level is 2" Below the Skimmer.

Please Note:

- A Gasket **MUST** be placed between the Skimmer Face Plate and the liner. Continue filling the pool until two-thirds of the skimmer Face Plate is covered with water.
- The liner **CAN NOT** be cut out from the center of the Face Plates until Face Plates and the Filtration System have been installed.

Remove the Nut from the Light Fitting and slide it off Cable. Install the Cable and Fitting as described in STEP #19, page 16. Remove the Clear Lens from the Light Fitting (*be careful not to scratch lens*).
 * Continue to build the pool through STEP #24, page 20. Using the Inside Edge of the Face Plate as a guide be Extremely careful and cut out the liner (*with a razor*) from the center (Inside) of the Light Face Plate. Thread the lens into the fitting. Snug the lens with Channel Lock Pliers gripping on the 2 Flats (*it is best to remove the nut holding the Fitting into the wall and hold the fitting from turning by hand, a large pair of Channel Lock Pliers or a Strap Wrench*). **DO NOT Over-Tighten**. Loosen the Acorn Nut on the Illuminator Cover and insert the Aluminum Cable End into the Heyco Connector. Make sure there is 1/4"– 1/2" gap between the Cable End and the internal Housing then tighten the Acorn Nut (Refer to Figure 25-1). Mount the Illuminator Box on a Post or on the Deck. Please Note: The Illuminator Box **MUST** be a Min. of 5' from the pool wall. Follow all other instructions supplied with the light.

Cable Protection Option:

Remove the Clear Lens from the Light Fitting (*be careful not to scratch lens*). Pull the Cable out of the Fitting. Install the Fitting as described in STEP #19, page 16. Thread a Male Adapter into the Light Fitting. Tighten by hand or with a pair of large slip-joint pliers. **DO NOT Over-Tighten**. Measure and cut pieces of 1-1/2" PVC Pipe (*with necessary elbows etc.*) to fit between the light and the Illuminator Box. A typical plumbing layout is shown in Figure 25-3 (*this may be altered based on finished grade and/or deck requirements*). Feed the Cable through the Light Fitting in the wall, PVC pipe and fittings while you assemble them working from the pool to the Illuminator Box. It is **NOT** necessary to glue the joints. The plumbing is to protect the Fiber Optic Cable from potential damage and is **NOT** open to the water. Check to make sure the Fiber Optic Cable extends 1/32" Max. past the Acorn Nut and check the tightness of the Acorn Nut to verify that it is secure on the Cable (Refer to Figure 25-2) **DO NOT Over-Tighten**. Push the Cable and Connector into the Fitting until the Clear Washer contacts the Rib in the center. Continue from the * above. Silicone around the Fiber Optic Cable where it enters the 1/2" x 1-1/2" Reducing Bushing when installation is finished, this will keep water and insects from entering the plumbing. Follow all other instructions supplied with the light.

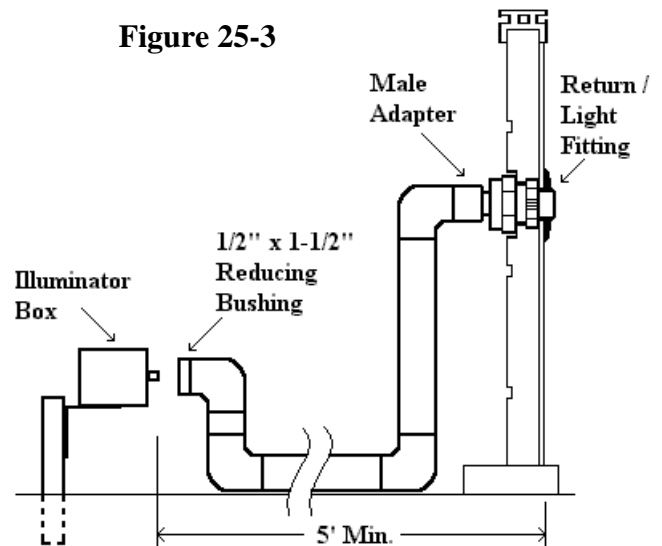
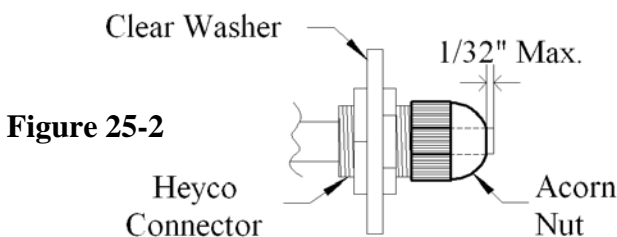
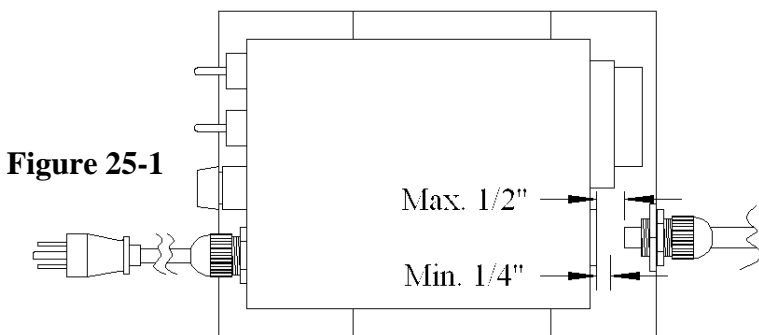

STEP #26

Place a coping clip over all coping joints (Refer to Figure 26-1). To install a coping clip insert the inside lip into the liner groove of the coping (1). Pull outward on the outside leg of the coping clip (2) until the locking tab will clear the cover groove. Push downward to snap clip into place (3) (Refer to Figure 26-2). To remove a coping clip, pull outward on the outside leg to release the locking tab from cover groove (2), lift up outside leg and push inward.

Figure 26-1

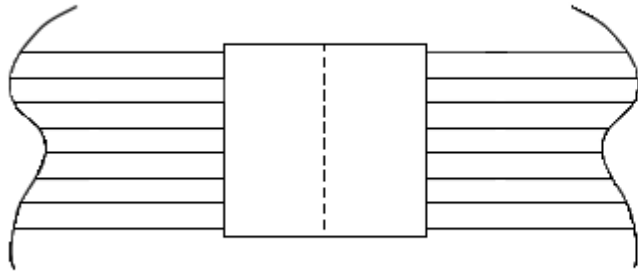
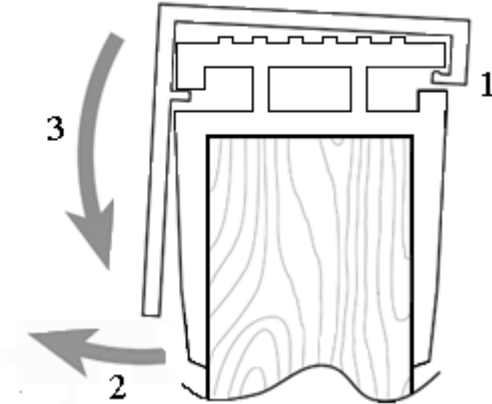

Figure 26-2



STEP #27

Assemble filter and ladder as per their individual instruction manuals.

STEP #28

Be extremely careful and cut out liner (*with a razor*) from the center (*Inside*) of the skimmer, return and light face plates. Use the Inside Edge of the face plate as a guide. Install water directional flow fitting in the return fitting.

STEP #29

Safety Placard MUST be installed where entrance or ladder to pool is located. No Diving Stickers MUST be placed on the liner. Space them evenly around the perimeter just below the coping.

STEP #30

After the pool is full of water, test the water for proper water balance. Proper sanitation levels (*Chlorine or Bromine*) should be maintained at all times. Improper ph will shorten the life of your liner and cause irritation to the skin and eyes! Follow all instruction for chemicals exactly. **DO NOT** place Chlorine or Bromine directly on liner, as bleaching will occur.

**CAUTION - REMEMBER, DO NOT JUMP or DIVE !!!!!!!!!!!
THIS POOL IS FOR SWIMMING ONLY!**

**SERIOUS SPINAL OR OTHER INJURY CAN RESULT FROM DIVING,
JUMPING, SLIDING, WALKING / SITTING ON TOP OF POOL WALL THIS POOL HAS BEEN
DESIGNED FOR SWIMMING ONLY!**

**PLEASE REMEMBER TO FILL OUT, SIGN AND RETURN ALL
WARRANTY/REGISTRATION CARDS.**